



The European Union's Tacis TRACECA programme
for Armenia, Azerbaijan, Bulgaria, Georgia, Kazakhstan, Kyrgyzstan, Moldova, Romania, Tajikistan, Turkey,
Turkmenistan, Ukraine, Uzbekistan

Review of Railways Rehabilitation in Central Asia

for Kazakhstan, Kyrgyzstan, Tajikistan and Uzbekistan

Module B – Detailed Design and Tender

Documents of the rehabilitation measures for the

Lugovaya – Kyrgyz border railway section

(Kazakhstan) – DRAFT

July 2005



This project is funded by
the European Union



A project implemented by
Italferr S.p.A.

Report cover page

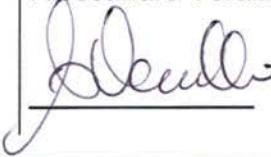
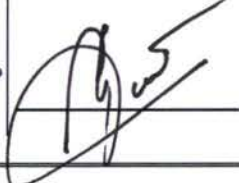
Project Title: Review of Railway Rehabilitation in Central Asia			
Project Number: 65290 – EuropeAid/116151/C/SV/Multi			
Countries: Kazakhstan, Kyrgyzstan, Tajikistan and Uzbekistan			
	Local operators	EC Consultant	
Name:	Republican State Enterprise "KAZAKHSTAN TEMIR ZHOLY" <i>Mr. Talaspekov K.S.</i>	<i>ITALFERR S.p.A.</i>	
Address:	98, Pobeda av., 473000 Astana Kazakhstan	via Marsala, 53/67 – 00185 Rome – Italy Akhunbabaeva ul, 15 – 700047 Tashkent – Uzbekistan	
Tel:	(3172)935002	+39.06.49752721 +998.71.1321237	
Fax:	(3172) 935836	+39.06.49752209 +998.71.1321286	
		E-mail: a.veralli@italferr.it italferr@litel.uz	
Contact Person:		Project Director Alessandro Veralli	Team Leader Paul Pezant
Signature:	_____		

Date of report: 31 July 2005

Authors of report: Project Team

EC M & E team	_____	_____	_____
	[name]	[signature]	[date]
NCU Kazakhstan	_____	_____	_____
	[name]	[signature]	[date]
TACIS Bureau [task manager]	_____	_____	_____
	[name]	[signature]	[date]

ABBREVIATIONS

ABLS	Automatic Block Line System
ADB	Asian Development Bank
ALC	Automatic Level Crossing
BC	Border crossing
CAR	Central Asian Republic
COTIF	Convention concerning the International Transport of Goods by Rail
CIS	Commonwealth of Independent States
CTC	Central Traffic Control
CWR	Continuous Welded Rail
EAEC	Euro Asian Economic Community
EBRD	European Bank for Reconstruction and Development
EC	European Commission
ECE	UN Economic Commission for Europe
ECO	Economic Cooperation Organisation
ECMT	European Council of Ministers of Transport
EDD	Unified Transit Tariff
EIRR	Economic Internal Rate of Return
ERII	Electric Relay Interlocking Installation
EU	European Union
FSU	Former Soviet Union
GDP	Gross Domestic Product
IGC	Intergovernmental Commission TRACECA
IMF	International Monetary Fund
IRU	International Road Transport Union
IsDB	Islamic Development Bank
JBIC	Japanese Bank for International Cooperation
KAZ	Kazakhstan
KGZ	Kyrgyz Republic
KTZ	Kazakhstan Temir Zholy (Kazakhstan national railways)
MLA	Multilateral Agreement on International Transport for Development of TRACECA
KZT	Kazakhstan Tenge
LC	Level Crossing
MKDII	Mechanic Key dependent Interlocking Installation
MOTC	Ministry of Transport and Communications
MTT	International Railway Tariff
OECD	Organisation of Economic Co-operation and Development
OSJD	Organisation for the Cooperation in Railways (based in Varshaw)
PRC	People's Republic of China
PW	Permanent Way (rails, sleepers, fastenings, ballast)
SIS	Static Interlocking System
SMGS	Agreement on International Railway Freight Transport
SPECA	Special Programme for the Economies in Central Asia
TA	Technical Assistance
TACIS	Technical Assistance for the Commonwealth of Independent States
TAJ	Tajikistan
TAR	Trans-Asian Railway
TEU	Twenty Foot Equivalent Unit
TIR	Transport International Routier
TOR	Terms of Reference
TRACECA	Transport Corridor Europe Caucasus Asia
UIC	Union International des Chemins of Fer (based in Paris)

UN	United Nations
UNDP	United Nations Development Programme
UNESCAP	United Nations Economic and Social Commission for Asia and the Pacific
USAID	United States Agency for International Development
USD	United States Dollar
UTY	Uzbek Temir Yullari (Uzbekistan national railways)
UZB	Uzbekistan
WTO	World Trade Organisation

TABLE OF CONTENTS

Executive summary	i
1. Project synopsis	3
2. Introduction	6
3. Description the present situation	8
3.1 Permanent Way and earthworks	8
3.2 Stations	17
3.3 Level Crossings	18
3.4 Structures and Drainages	18
4. Detailed Design of permanent way and civil works (Lot 4.1)	19
4.1 Methodology for the line construction (Permanent Way)	22
4.1.1 Methodology 1	22
4.1.2 Methodology 2	25
4.2 Methodology for rail welding	28
4.2.1 Thermic welding	28
4.2.2 Electric Flash-butt Welding	31
4.2.3 Formation of Continuous Welded Rails (CWR)	32
4.3 Bill of quantities	33
4.4 Costs estimates	35
4.4.1 Unit costs	35
4.4.2 Unit costs for materials	37
4.4.3 Unit costs for machines	38
4.4.4 Unit costs for local manpower	39
4.4.5 Cost calculation flow	40
5. Implementation schedule	42
6. Tender Documents	44
6.1 Introduction	44
6.2 The adopted philosophy for procurement	44
7. Conclusions	47

ANNEXES

Annex A: Lot 4.1 – Permanent Way and Civil Works

Executive summary

After the development of the Feasibility Study (March 2005), project activities aimed at producing tender documents suitable for international tender for rehabilitation measures for the Lugovaya - Kyrgyz Border railway line. The present document is to report the conclusions of such activities of Detailed Design and Tender Documents.

Historically the section under study belongs to the line Lugovaya – Bishkek – Balykchi as it is shown in the following figure.

Figure - The Lugovaya – Bishkek – Balykchi railway line



After the collapse of the former Soviet Union, the line has been split into two sections because of the introduction of the national border between Kyrgyzstan and Kazakhstan: the Lugovaya - border (61 km) and the border – Bishkek – Balykchi (322 km).

The administrative change could not change so much the situation since the two sections are still working in conjunction. Furthermore services along the line are operated up to Lugovaya by the Kyrgyz Railways and so they will be up to 2007 at least.

Besides this fact, improvements along the section from Balykchi to the border should be certainly managed by the Kyrgyz Railway Administration while the section up to Lugovaya belongs to the Kazakhstan Railways and it is likely that after 2007 improvement will be managed by such organisation. Consequently the issue of the competence has required to consider two different

Feasibility Studies and two different Tender Documents for rehabilitation measures concerning sections of the same line.

The development of activities for the Detailed Design and Tender Documents preparation has started from the feasibility study delivered in March 2005.

The rehabilitation works of the Lugovaya – Kyrgyz border section regards the renewing of the permanent way and some minor civil works and in details they includes:

- a. civil works concerning earthworks and drainages;
- b. permanent way replacing works (for line and stations, there including replacement of 1 turnout);
- c. rail welding and mechanical tension regulation;
- d. re-aligning, re-levelling and ballasting;
- e. civil works concerning re-pavement of some level crossings (L.C.). No elimination of level crossing by substitution with bridges has been envisaged for the low traffic both on the railway line and on the interfered roads.

Costs for the rehabilitation works have been estimated to be of 14,8 millions of US\$ and due to the entity of the investments and the good financial performance of the Kazakh railways, the Consultant has recommended to implement the project using internal funds.

Because of the nature of the works to be performed, the tender should be an international tender for "Design-Build and Turn Key Contract ". According to this rationale the Consultant has developed the tender documents using international standards (ADB guidelines) and including:

A - prequalification of bidders, and

B - tender for Design-Build and Turn Key Contracts with Single Stage procedure

Such approach of using international standards leaves open the possibility of adopting guidelines of procurement of bodies other than ADB. Thus the approach doesn't prevent the Beneficiary to implement the project using other guidelines (i.e. World Bank, EBRD, national, etc.) simply taking the core part of the tender document, namely the technical drawings and specifications, and embedding them into a different set of standards documents.

The Consultant has presented such documents in a separate Annex A which can be straight used for the tender just including some basic additional information from the Beneficiary (i.e. employer's name and address, representative of the employer, deadline for presentation, etc).

1. Project synopsis

Project Title:	Review of Railway Rehabilitation in Central Asia
Project Number:	65290 – EuropeAid/116151/C/SV/Multi
Country:	Kazakhstan, Kyrgyz Republic, Tajikistan, Uzbekistan

Wider project objectives: The development of viable, secure, safe and competitive transport routes linking the countries of Central Asia with Europe and other neighbouring countries. Strengthened border management capacity facilitating economic development, the movement of people and goods and the prevention of organised crime.

The object of the project is to carry out:

Module A / Analysis of the relevant national railway transport plans and any regional railway transport planning provisions.

Module B / Preparation of Technical and Economic Justifications to support and to attract the investments for the rehabilitation of railway lines in the Kyrgyz Republic, Kazakhstan and Uzbekistan for the purpose of increasing transportation capacities of these areas. Preparation of Feasibility study of measures for the maintenance, rehabilitation and renewal of the freight wagon fleet of the Tajik Railways.

Specific project objectives:

The project will carry out:

Module A /

- Overview of relevant traffic flows and forecasts, with special attention on freight transport from Central Asia towards Europe especially through TRACECA corridor;
- Identification of weaknesses and bottlenecks;
- Investigation on the cross-border elements, including co-operation in exchange of data and in customs (also with Afghanistan);
- Evaluation of multi-modal dimensions and possibilities for inter-operability;
- Harmonisation of standards and of operating procedures, with particular attention to compatibility with EU standards, in particular with regard to safety and security standards for the transportation of dangerous goods and oil products.

Module B /

Technical and Economic Feasibility Studies for the rehabilitation and construction of new railways lines. Pursuant to the Technical and Economic Justification data there will be prepared the loan applications

to the lending banks for the allocation of investments to implement the projects.

Feasibility Study of measures for the maintenance, rehabilitation and renewal of the freight wagon fleet of the Tajik Railways.

Planned outputs:

Module A /

- Recommendations concerning multimodal transport
- Recommendations on harmonisation of standards and operating procedures and interoperability.
- Recommendations on improvements of border-crossing procedures.
- Traffic forecasts.
- Tentative prioritisation of recommended actions.

Module B /

- Technical and economic feasibility study of the railway line sections previously identified in Kazakhstan, Kyrgyzstan and Uzbekistan.
- Draft tender document for the same sections.
- Definition of a policy for the maintenance, rehabilitation and renewal of wagons in Tajikistan.
- Feasibility study and preparation of tender documents for rehabilitation and renewal of the existing workshops and maintenance plants in Tajikistan.

Project activities:

Module A /

- A.1 – Collection and review of transport and economic studies. Data collection
- A.2 – Overview of traffic flows
- A.3 – Identification and review of physical, geopolitical, social and environmental issues
- A.4 – Analysis of national railway transport plans and regional railway transport planning provisions.
- A.5 – Traffic forecasts – Identification of capacity bottlenecks
- A.6 – Investigation of border-crossing issues – Recommendations for improvement at borders
- A.7 – Review of multimodal transport – Identification of development bottlenecks – Recommendations for improved services
- A.8 – Harmonisation of standards and of operating procedures – Recommendations on standards adaptation and improved interoperability
- A.9 – Selection of railway section to be submitted to feasibility study under Module B
- A.10 – Discussion with the Project Partners representatives
- A.11 – Refining output of Module A

Module B /

Activities to be developed in Kazakhstan, Kyrgyzstan and Uzbekistan:

- B.1 - Traffic Analysis

- B.2 - Technical Feasibility
- B.3 - Environmental Impact
- B.4 - Economic Viability
- B.5 - Detailed Design
- B.6 - Rehabilitation/construction implementation schedule
- B.7 - Draft tender documents preparation

Activities to be carried out in Tajikistan:

B.8 - Feasibility Study of measures for maintenance, rehabilitation and renewal of the freight wagon fleet of the Tajik Railways

Project starting date: 1 March 2004

Project duration: 18 months

2. Introduction

The present document is to report the conclusions of the activities of Detailed Design and Tender Documents developed following the feasibility study of the rehabilitation measures for the Lugovaya – Kyrgyz border railway section in Kazakhstan delivered in March 2005.

Historically the section under study belongs to the line Lugovaya – Bishkek – Balykchi as it is shown in the following Fig. 2 – 1.

Fig 2 – 1 - The Lugovaya – Bishkek – Balykchi railway line



After the collapse of the former Soviet Union, the line has been split into two sections because of the introduction of the national border between Kyrgyzstan and Kazakhstan: the Lugovaya - border (61 km) and the border – Bishkek – Balykchi (322 km).

The administrative change could not change so much the situation since the two sections are still working in conjunction. Furthermore services along the line are operated up to Lugovaya by the Kyrgyz Railways and so they will be up to 2007 at least. This is why the report is making reference to the whole line.

Besides this fact, improvements along the section from Balykchi to the border should be certainly managed by the Kyrgyz Railway Administration while the section up to Lugovaya belongs to the Kazakhstan Railways and it is likely that after 2007 improvement will be managed by such organisation. Consequently the issue of the competence has required to consider two different Tender Documents for rehabilitation measures concerning sections of the same line.

As a matter of facts the uncertainties for the competence has been an issue also for the project development. The Kyrgyz part is interested in having a good connection with the rest of the rail world but can't afford investments especially in a country other than Kyrgyzstan. The Kazakh part has stated that they will take care of the section when it will be returned under the Kazakh operation (likely after 2007). Despite the line moved for different reasons the interested of both parties, the results of the present study will be used in a later stage. The development of activities for the Detailed Design and Tender Documents preparation has started from the feasibility study delivered in March 2005.

The proposed option for Lugovaya – Kyrgyz border section ("Option 1" of the Feasibility Study) is the natural complement of the measures envisaged beyond the border (Kazakh border – Bishkek 2 section), as it foresees the demolition of the existing permanent way of the line, included the running tracks of the stations, the excavation of a layer of about 0.6 m of the existing material, the formation of 2 new layers of sandy gravel material 0,2 m thick and of ballast 0,3 m thick, the laying down of new concrete sleepers, the installation of new or recovered P65 rails, the formation of continuous welded rails, the replacement of the existing P50 switches with P65 tg1/11 type ones on running tracks.

The Consultant has consequently undertaken the Detailed Design and the Tender Documents preparation for the best option selected during the Feasibility Study as it above described.

The option considers in particular the categories in which the whole rehabilitation works can be divided to be:

- civil works concerning earthworks and drainages;
- permanent way replacing works (for line and stations);
- rail welding and mechanical tension regulation;
- re-aligning, re-levelling and ballasting;
- civil works concerning re-pavement of some level crossings (L.C.).

All those activities are supposed to be developed by a Contractor on the basis of an international tender using a Design - Build contract.

Therefore only one lot has been considered:

Lot 4.1 – Permanent Way and Civil works

The Consultant has developed tender documents packages using international standards (ADB standards) using the following steps:

- A - prequalification of bidders, and
- B - design-build and turnkey tender (single stage)

Such approach of using international standards leaves open the possibility of adopting guidelines of procurement of bodies other than ADB. Thus the approach doesn't prevent the Beneficiary to implement the project using other guidelines (i.e. World Bank, EBRD, national, etc.) simply taking the core part of the tender document, namely the technical drawings and specifications, and embedding them into a different set of standards documents.

The Consultant has presented such documents in separate Annex A which can be straight used for the tender just including some basic additional information from the Beneficiary (i.e. employer's name and address, representative of the employer, deadline for presentation, etc).

3. Description the present situation

3.1 Permanent Way and earthworks

The Lugovaya-Kyrgyz border (Chaldovar) railway line section (60.9 km), belongs to the line Lugovaya-Bishkek-Balykchi (322.354 km) which is located part in Kazakhstan and part in Kyrgyzstan.

The Lugovaya – Kyrgyz Border line is single track, mainly straight, not electrified, with 5 stations (Lugovaya included) between 8 and 19 km distant.

Construction and development of railways in Kyrgyz Republic was implemented by stages. Lugovaya – Piskek (Bishkek 1) was put into operation in 1924, according to the project of construction of Turksib line (Turkestan – Siberia). Due to some unclear reasons, the project was then changed and the construction of railways was carried on according to the economic possibilities, necessities and needs: Pishpek – Frunze (Bishkek 2) in 1929, Frunze – Kant in 1932 to connect a sugar refinery, Kant – Tokmak in 1941, Tokmak – Bystrovka in 1942, Bystrovka – Ribachye (Balykchi) in 1950. The station of Merke was built in 1924 along with the line Almata-Piskek. With the development of various enterprises of the region, the station was later expanding for traffic increase. Munke station was built in 1932.

After the collapse of former Soviet Union (1991), the Lugovaya – Kyrgyz border section, in spite of being in Kazakh republic territory, continue up till now to be maintained and operated by Kyrgyz railways. Meetings were held recently between Kazakh and Kyrgyz governments to agree the passage of this section to the operation and maintenance of Kazakh railways.

Alignment and gradients

The total length of Lugovaya - Kyrgyz border section is 60.95 km.

The alignment is shown in Fig. 2-1: mostly on straight (1.27 km of curves out of 60.95 km in length). Every circular curve is provided with parabolic transition curves at the beginning and at the end.

- The minimum curve radius is 1.000 m.
- The maximum cantilever is 80 mm.
- The maximum allowed load is 23 t/axle.

The Tab. 3.1 – 1, shown in the following pages, contains all the relevant data about the line:

- curves and their characteristics (length, deviation angle, radius, cant),
- level crossings location,
- stations with start, end and centre (building) chainage. The chainage is referred to the first and last turnout blades.

Tab. 3.1 - 1

Element	Start (km)	End (km)	Station centre (km)	Cant (cm)	Deviation angle (degree)	-60	Radius (m)	Curve length (m)	Transition length (m)
Lugovaya	3626.329	3627.497	3626.329						
L.C.	3627.514								
Curve	3627.893	3627.934		0	1	18	1800	40	0
Curve	3628.076	3628.117		0	1	18	1800	40	0
L.C.	3634.355								
L.C.	3637.318								
R-3639	3637.725	3638.964	3637.726						
Curve	3643.587	3643.757		3	4	36	2250	200	20
L.C.	3646.386								
Munke	3647.563	3648.624	3648.109						
L.C.	3656.903								
Curve	3660.877	3661.066		8	8	30	1000	188	40
Curve	3651.239	3651.430		5	8	37	1000	191	40
Curve	3651.675	3651.815		4	3	55	1300	140	40
Curve	3662.372	3662.509		4	4	17	1300	137	40
Curve	3664.885	3665.194		4	3	55	2800	209	40
L.C.	3665.427								
Merke	3665.470	3666.683	3666.012						
L.C.	3666.976								
L.C.	3677.868								
L.C.	3681.525								
Curve	3684.024	3684.157		0	0	25	18500	133	0
Chaldovar	3685.746	3686.816	3686.324						
L.C.	3686.956								

Line formation

The line formation from Lugovaya to Kyrgyz border is constituted by embankments 1+3 m height.

The standard cross section of the formation is reported on Fig. 3.1 – 1 in which a slope of about 6% towards both sides, starting from a central strip 2,3 m wide, can be observed.

The top surface of the embankment width varies from 6,0 m to 7,1 m.

Fig. 3.1 – 1

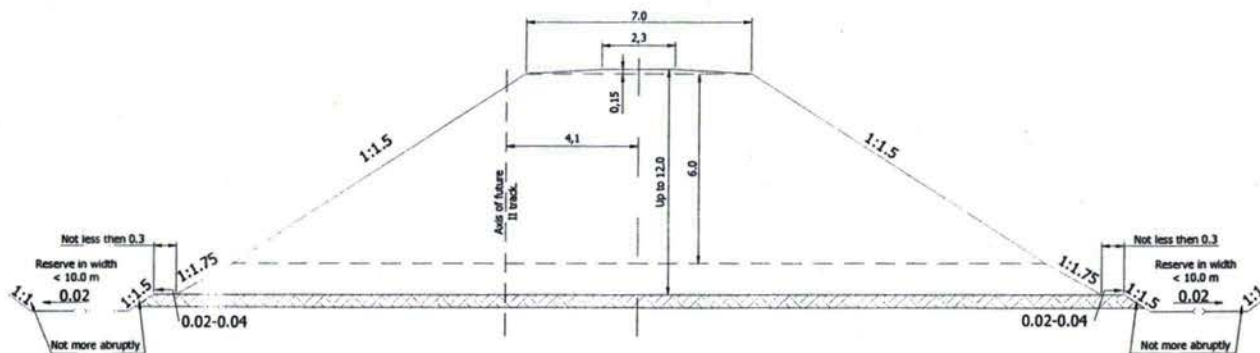

Typical cross structure of embankment in height up to 12 m from clay soils, fine and powdery sand and it is easy weathered rock.
The note: At erection of embankments from dry sand with a corner of a natural slope less than 340 their slopes are arranged more gentle slope.

Superstructure

The typical superstructure cross-sections on straight track and on curve are shown in Fig. 3.1 – 2. On the top surface of the embankment is laid down a sandy gravel layer 0,2+0,3 m thick, and a ballast layer 0,20+0,35 m thick under sleepers.

Along the main line of the track section these are the technical characteristics:

- the sandy gravel layer and the ballast layer are, respectively, 0,2 and 0,3 m thick,
- mixed wooden and concrete sleepers are installed (see Fig. 3.1 – 3); they are laid down at a distance of 0,54 m / 0,50 m between their axles on straight / on curves of radius less than 1200 m (1840 / 2000 sleepers per km),
- P65 type of rails are laid down (see Fig. 3.1 – 4).
- fastenings rail-wooden sleepers and rail-reinforced concrete sleepers are shown in Fig. 3.1 – 5.

Fig. 3.1 – 2

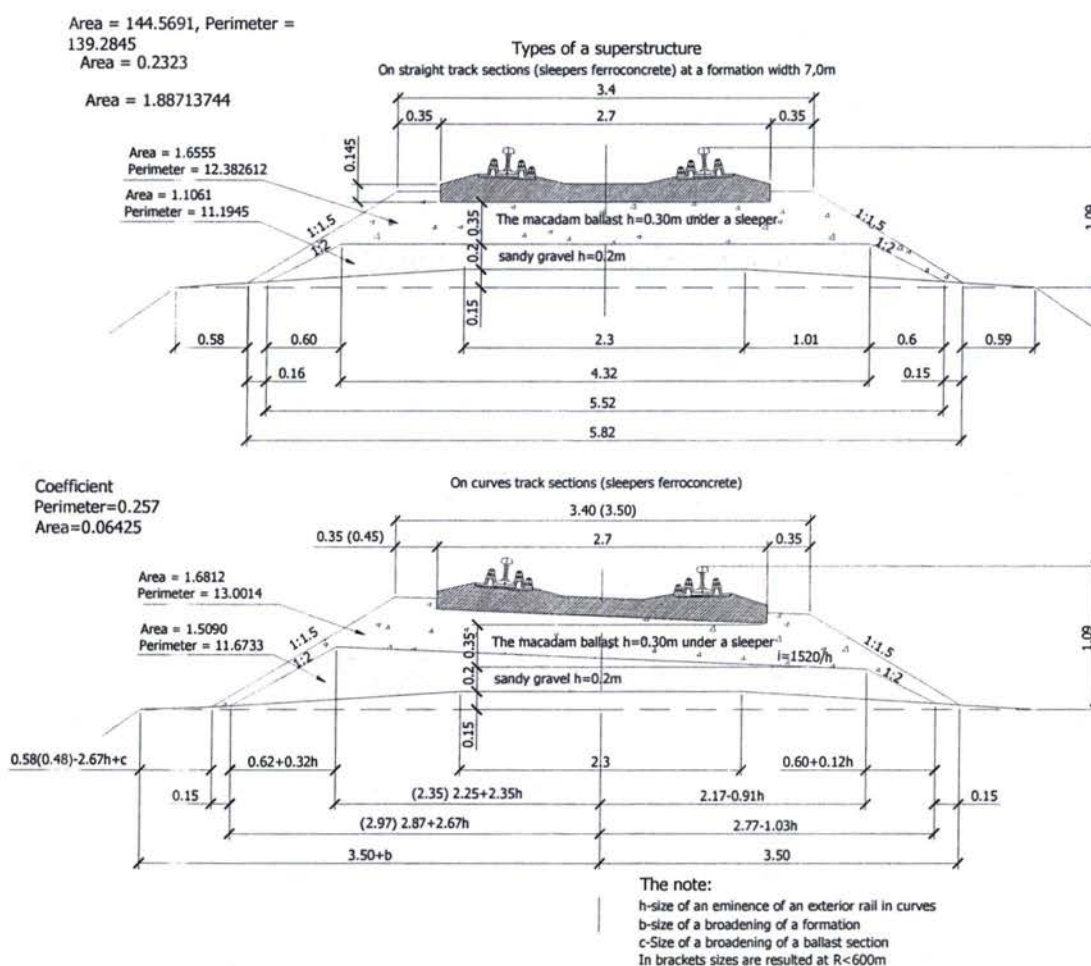

Fig. 3.1 – 3

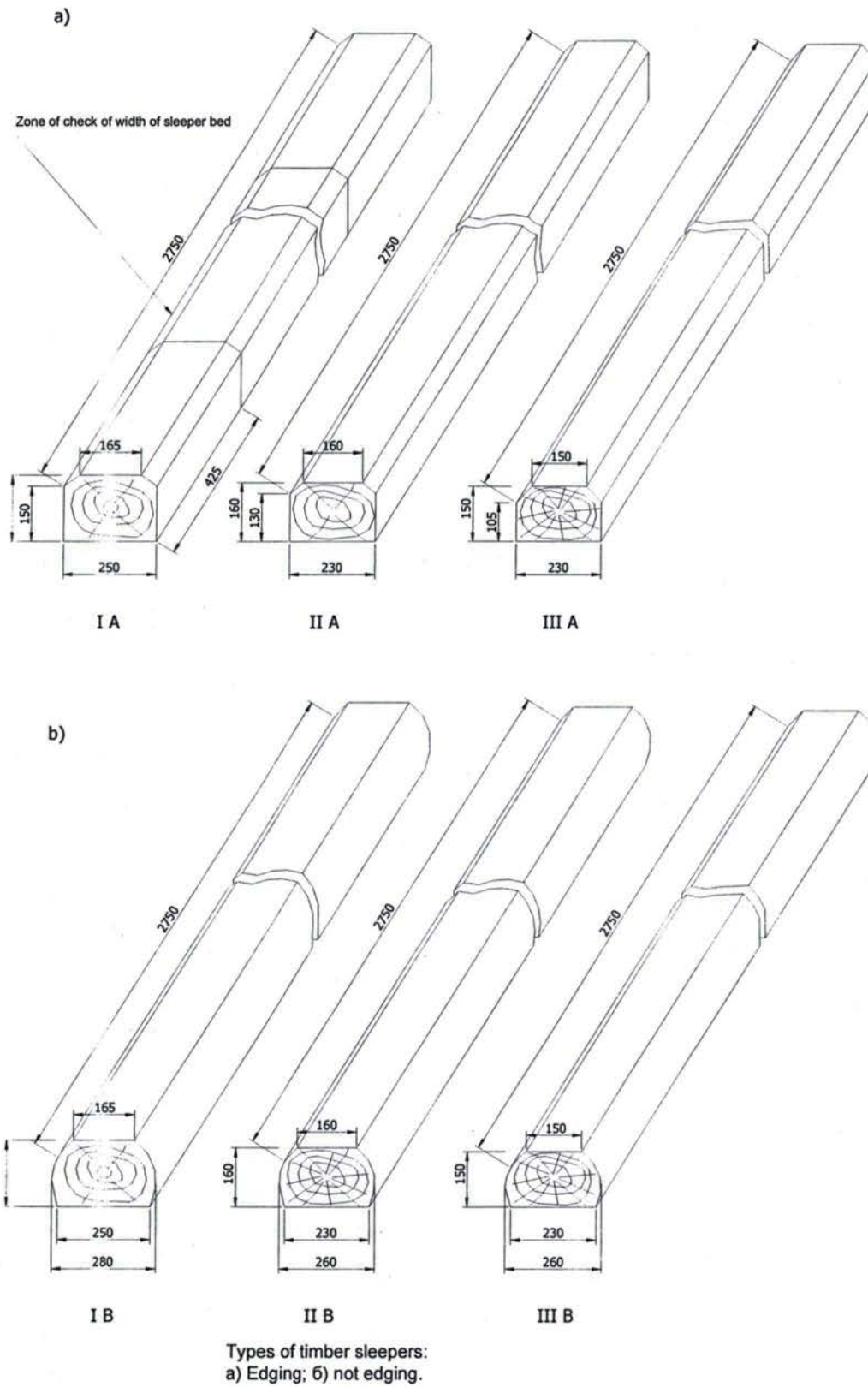
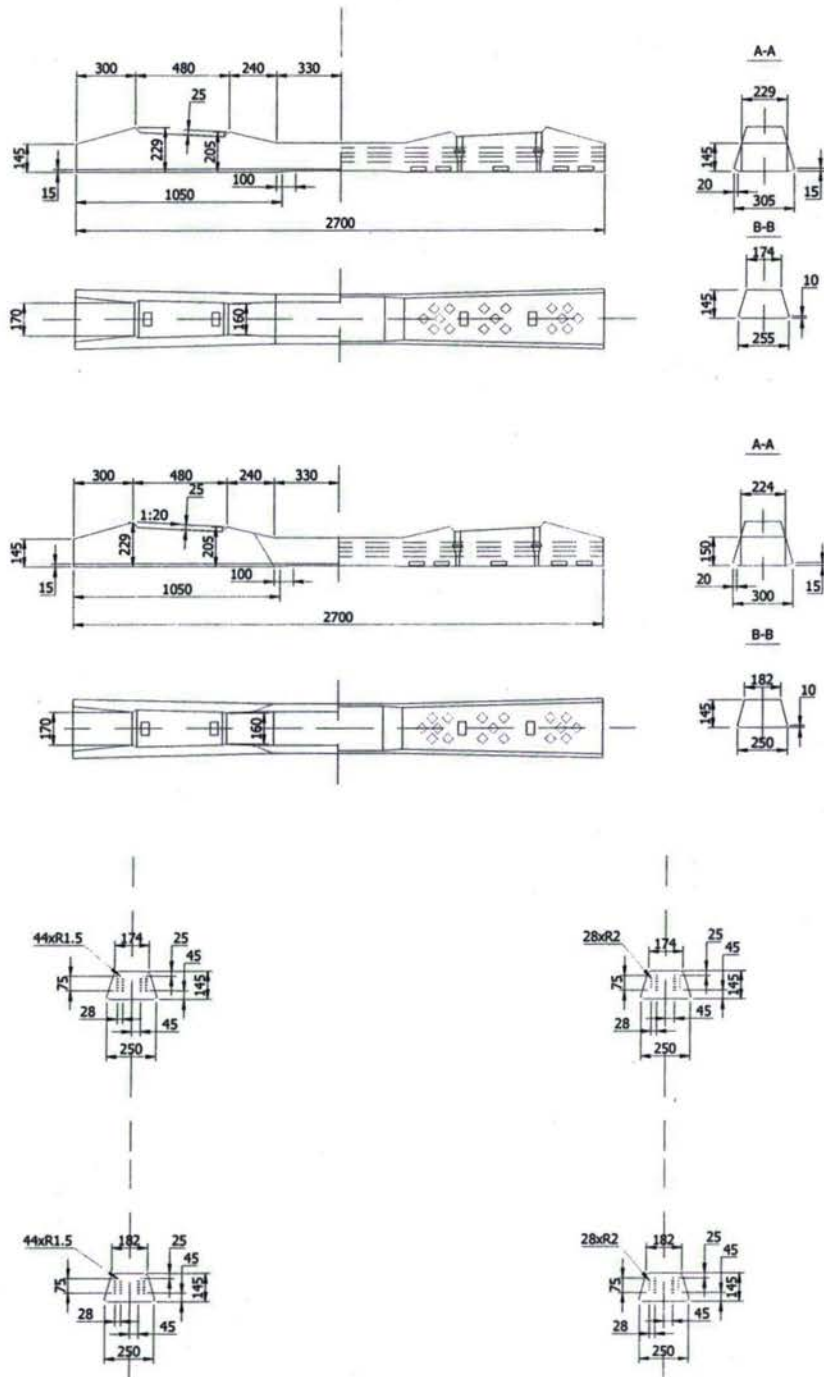

Fig. 3.1 – 4



Design of ferroconcrete sleepers
 a - such as C-73-1; b - such as C-73-2; c - cross sections and reinforcing of sleepers C-73-1; d - cross sections and reinforcing of sleepers such as C-73-2.

The appendix 8-4

Fig. 3.1 – 5

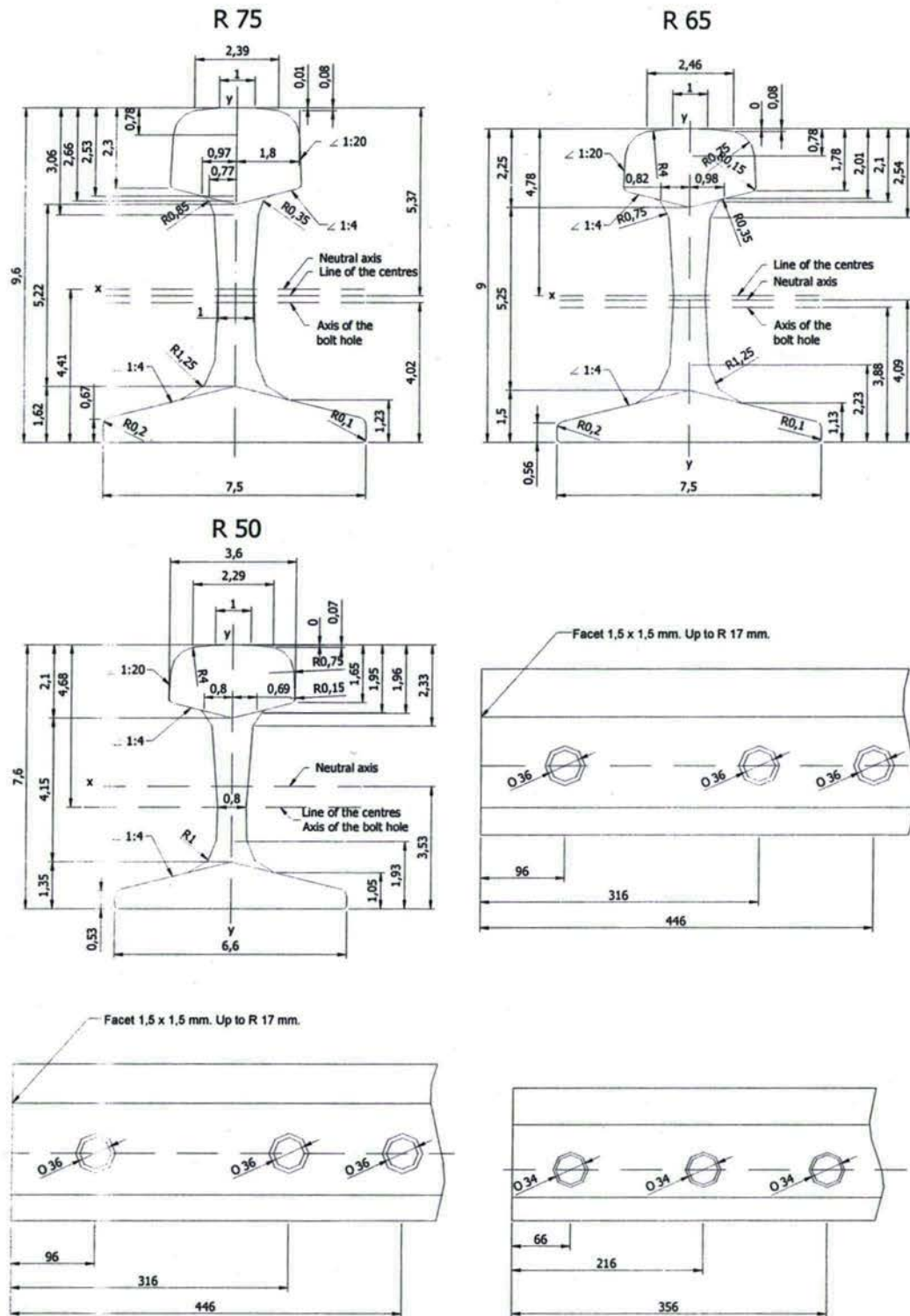

Cross profiles of standard rails (R75 R65 R50)

Normally rails are provided in 25 m bars; so, when they are laid down, a joint has to be done every 25 m. To reduce the hammering at the passage of trains, the joints on one rail are displaced 3 cm from the relevant ones on the other rail along the track

On lines equipped with concrete sleepers, a great reduction of hammering effect can be obtained by welding rails in long bars (continuous welded rails, cwr).

The great advantages of this technique, which will be described in the next paragraphs, are the increase in comfort for passengers and considerable reductions in noise, in wearing out of rails and rolling stocks, in costs of maintenance.

According to Russian standards the maximum length of welded rail bars in Central Asia countries is 900+1000 m. At the beginning and at the end of the long welded bars a sequence of joints and short bars 12,5 m long has to be laid down to allow a limited "expansion" of the long bar at the highest levels of temperature. The schemes to be implemented are reported on Fig. 3.1 – 6:

Fig. 3.1. - 6
(measures in m)

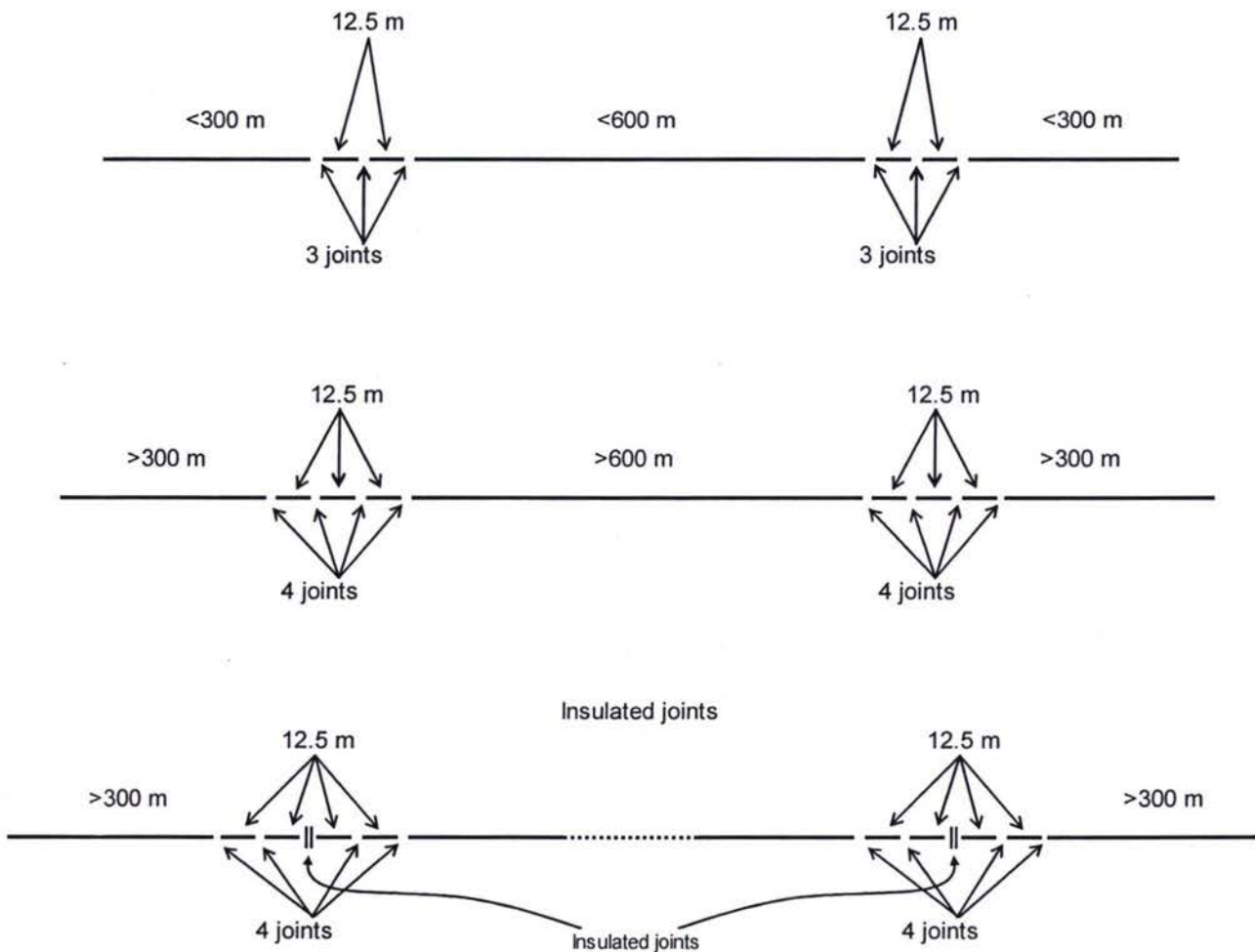

The situation of the existing permanent way on line and into stations on the studied section can be summarised as it follows (see Table 3.1 – 2).

Table 3.1 – 2 Existing permanent way on line and stations

Rehabilitation works for Lugovaya-Balykchi Line - Lugovaya-Kyrgyz border section								
Permanent way and turnouts type								
Stations				PW type				
Name	start km	end km	Line and station main lines			Stations turnouts		
			Rail type	Sleepers	Length	on main track		
N.					(m)	P65 1/11	P50 1/11	
						(N.)	(N.)	
1	Lugovaya	3626.329	3627.497	P65	W/C	1168		
		3627.497	3637.725	P65	W/C	10228		
2	R-3639	3637.725	3638.964	P65	W/C	1106	4	
		3638.964	3647.563	P65	W/C	8599		
3	Munke	3647.563	3648.624	P65	W/C	928	4	
		3648.624	3665.470	P65	W/C	16846		
4	Merke	3665.470	3666.683	P50	W/C	1080	3	1
		3666.683	3685.746	P65	W/C	19063		
5	Chaldovar	3685.746	3686.816	P65	W/C	1003	2	
		3686.816	3687.280	P65	W/C	464		
	<i>border</i>		<i>3687.280</i>					
						13	1	

The following table resumes the permanent way type in stations (main track) and line.

Table 3.1 - 3

PW type Kazakhstan		
	Line	Stations main track
W/C+P65	55,200	4,204
W/C+P50		1,080

From the table could be observed that

- All the line (55,2 km) is equipped with P65 rails on mixed wooden/concrete sleepers,
- All the stations are equipped with P65 rails on mixed wooden/concrete sleepers with the exception of Merke station which is equipped with P50 rails (1,08 km out of 5,28 km).

No continuous welded rails are implemented along the section.

The existing turnouts are P65 tg 1/11 type on the station main lines from Lugovaya up to Kyrgyz border, with the exception of one turnout P50 tg 1/11 type installed in Merke station.

In total, on station main track the following turnouts are currently installed:

- 13 P65 tangent 1:11,
- 1 P50 tangent 1:11.

PW defects of the line

The considered section is in quite good condition, nevertheless in the opinion of the Consultant an upgrade of the same level proposed for the Kyrgyz section of the line has to be foreseen.

On the existing state of PW the Consultant stresses that:

- the general condition of PW leads to current speed restrictions;
- 50% of wooden sleepers are to be changed, their bad condition does not permit the use of machine for tamping;
- fastening devices on wooden sleepers are old and their fastening action reduced;
- rail junctions are old and worn out; the hammering effect at the passage of trains led to permanent deformation and damages of the rail bars ends;
- original conditions of the alignment and profile are to be recovered;
- in parts of the line the lateral paths of 0,59 cm on both sides of the top embankment surface disappeared for the action of raining waters and blowing wind; consequently quantities of ballast fell down and were wasted;
- in many cases the shoulders of ballast on the sides of sleepers, that in normal conditions are 0,35+0,45 m wide, are non-existent;
- most of the ballast is extremely polluted with clayey soil and sand, particularly in stations;
- generally there are not drainage ditches.

Maximum speeds along the section

Conditions of permanent way elements can cause the necessity to reduce the maximum allowed speed on the lines. Generally this measure is taken when:

- the head of rails is worn out up to the admissible values,
- the ballast layer is highly polluted,
- the sleepers are no more in reliable condition for mechanical wear, decay and cracking,
- turnouts are obsolete and their elements worn out (in particular blades and crossings),
- existing cross section is greatly reduced by wind or rain water erosion,
- profile and alignment are far from the original designed ones,
- bridges and culverts needs interventions.

In the case of this section reductions of maximum speeds were imposed along all its length.

From the original 100/120 km/h speed for passenger trains and 90 km/h speed for freight trains, the maximum allowed speed, on all the considered section, is now 70 km/h.

For the original speed of the line, the Consultant has operated a detailed analysis based on the existing line geometrical value, aimed at calculating, per each curve and therefore per each section, the maximum admissible speed.

The following Table 3.1-4 shows the existing line geometrical maximum speeds, and the theoretical maximum speeds reached with the upgrading of some indicated curve cants (superelevation). Calculations have been carried out by taking into consideration the following values:

- maximum admissible value for "a_{nc}" (not compensated acceleration on curve)=0.55 m/sec²
- maximum admissible "a_{nc}" variation on the transition curves=0.20/0.15 m/sec³

These maximum speeds will be recovered with the proposed rehabilitation options.

Table 3.1 – 4 Existing and future curves parameters. Future speeds.

Rehabilitation works for Lugovaya-Balykchi Line - Lugovaya-Kyrgyz border section									
Existing and future line speed limits - curves modifications									
Existing situation						"with project" situation			
Curves			Existing cant	Existing R	Max alignment speed	Min length of transition curve	Operation Max speed	Cant to be increased	Future cant value
			(cm)	(m)	(km/h)	(m)	(km/h)		(cm)
Curve	3627,893	3627,934	0	1800	110	105,66	110		
Curve	3628,076	3628,117	0	1800	110	105,66	110		
Curve	3643,587	3643,757	3	2250	140	126,27	110		
Curve	3660,877	3661,066	8	1000	115	112,19	110		
Curve	3651,239	3651,430	5	1000	105	105,42	110	yes	6
Curve	3651,675	3651,815	4	1300	115	114,60	110		
Curve	3662,372	3662,509	4	1300	115	114,60	110		
Curve	3664,885	3665,194	4	2800	155	119,19	110		
Curve	3684,024	3684,157	0	18500	160	31,64	110		

Theoretical maximum speeds allowed by the mentioned curves, are shown in the following Table 3.1 – 5.

Table 3.1 – 5 Theoretical maximum speeds.

Rehabilitation works for Lugovaya-Balykchi Line - Lugovaya-Kyrgyz border section		
Theoretical maximum speeds		
Radius	Cant	Speed
(m)	(mm)	(km/h)
1000	80	110
1300	40	115
1800	0	110
2250	0	130
2800	40	170

3.2 Stations

General

The line Lugovaya - Kyrgyz border is provided with 5 stations with a distance between 20,3 km (longest section) and 10,4 km. Their main functions are:

- operation (train crossings and overtaking);
- train parking;
- rolling stock parking (for service, for shunting or for maintenance);
- passenger service.

The following Table 3.2-1 resumes the stations position and distances on the Lugovaya - Kyrgyz border section.

Table 3.2 – 1 Stations on the Lugovaya - Kyrgyz border section

Rehabilitation works for Lugovaya-Balykchi Line - Lugovaya-Kyrgyz border section					
Stations					
	Station name	Dimension (number of tracks)	Kind of station	Centre building chainage	Distance (km)
1	Lugovaya		large plant	3626,329	
					11,397
2	R-3639	3	small	3637,726	
					10,383
3	Munke	3	small	3648,109	
					17,903
4	Merke	4	medium	3666,012	
					20,312
5	Chaldovar	2	small	3686,324	
					0,956
	Kazakh border			3687,280	

3.3 Level Crossings

Along the Lugovaya – Kyrgyz border railway section a total of 10 level crossings is present.

The level crossing protection system is assured by crossing warning signals (traffic lights and Saint Andrew crosses) without barriers in 8 cases, with barriers protected by block signals in one case, with barriers protected by station signals in the last case.

The warning signalling system is automatic: track circuits detect trains and activate warning indications at level crossings.

The pavement of the level crossing area is typically made of concrete blocks or rarely of wooden sleepers.

Hereafter is listed the position of each level crossing:

Table 3.3-1 Position of each level crossing

Lugovaya – Kyrgyz border section		
Level Crossings		
1	L.C.	3627,514
2	L.C.	3634,355
3	L.C.	3637,318
4	L.C.	3646,386
5	L.C.	3656,903
6	L.C.	3665,427
7	L.C.	3666,976
8	L.C.	3677,868
9	L.C.	3681,525
10	L.C.	3686,956

3.4 Structures and Drainages

Along the entire Lugovaya – Kazak border there are 25 concrete bridges, 44 pipe culverts, 6 box culverts and 31 arch culverts. According to the Kyrgyz railway experts who are operating nowadays the line, only few of them are to be rehabilitated.

4. Detailed Design of permanent way and civil works (Lot 4.1)

The rehabilitation works of the Lugovaya – Kyrgyz border section regards the renewing of the permanent way and some minor civil works and in details they includes:

- a. civil works concerning earthworks and drainages;
- b. permanent way replacing works (for line and stations, there including replacement of 1 turnout);
- c. rail welding and mechanical tension regulation;
- d. re-aligning, re-levelling and ballasting;
- e. civil works concerning re-pavement of some level crossings (L.C.). No elimination of level crossing by substitution with bridges has been envisaged for the low traffic both on the railway line and on the interfered roads.

Therefore description of the present situation and detailed design have been limited to those aspects included in the Lot 4.1.

It is worth mentioning that the adopted tender documents for “design and build” gives to the construction contractor the full responsibility of developing the executive design following the so called “employer’s requirements”.

The detailed design performed by the Consultant is due just for formulating the employer’s requirement and not for other elaborations.

On the contrary the construction contractor is the sole responsible of the executive design and of the works implementation. In such circumstances, the detailed design made by the consultant has to be seen as a base/advise which doesn’t prevent the construction contractor to propose other works methodology and formulate their financial proposal accordingly.

The envisaged works for line rehabilitation are as follow:

- the demolition of the existing permanent way of the line, included the running tracks of the stations,
- the excavation of a layer of about 0.6 m of the existing material,
- the formation of 2 new layers of sandy gravel material 0,2 m thick and of ballast 0,3 m thick,
- the laying down of new concrete sleepers,
- the installation of new or recovered P65 rails,
- the formation of continuous welded rails,
- the replacement of the existing P50 switches with P65tg1/11 type ones on running tracks.

The interventions can be summarized as it follows:

- Topographic survey of the Lugovaya - Kyrgyz border (km 61),
 - from chainage km 3626,329 to km 3665,47 (km 39,1 - P65 rails w/c sleepers),
 - from chainage km 3665,470 to km 3666,683 (km 1,08 – P50 rails w/c sleepers),
 - from chainage km 3666,683 to km 3687,280 (km 20,5 – P65 rails w/c sleepers):
- demolition of existing P65/P50 rails and wooden/concrete sleepers (60,5 km),
- recover of P65 rail bars (118.400 m) and reusable concrete sleepers,
- excavation of a layer 0,6 m thick of material (172.691 m³),

- widening, if needed, the top surface of formation of 1.0m on both sides (15 km have been estimated, corresponding to 81,450 m³ of earth),
- laying down a layer 0,2 m thick of sandy gravel material (65.485 m³),
- installation of reinforced concrete sleepers (115.300 pieces),
- installation of P65 rails on the main lines, stations included (121.000 m, corresponding to 7,100 t, out of which 1,430 t new purchased for replacing the old P65 in bad conditions),
- laying down a layer 0,3 m thick of ballast (107.206 m³),
- regulation of mechanical tensions of continuous welded bars (121,0 km),
- formation of continuous welded rails (about 4,330 welds, 440 normal joints, 110 insulated joints),
- replacement of one P50tg1/11 switche with a P65tg1/11 one in Merke station,
- demolition of 10 level crossing pavements,
- rebuilding of 10 definitive level crossing pavements (the pavement is generally formed by 24 reinforced concrete blocks),
- final tamping, levelling, aligning, addition of ballast, if needed (61,0 km).

Location of the envisaged works along the line is given in Figure L4.1–1 of annexed Tender Documents while the following Table 4-1 gives a short description of the different works.

Table 4-1 – Infrastructures works for line rehabilitation

Code	Works	Description
1A	Topographic survey of the line and corrections of the existing alignment and profile.	Topographic survey to be carried out along the line, for a strip of 50+50m around the existing railway axis, production of the current status cartography, and detailed correction of the alignment and profile of the line. New plan profile in scale 1:1,000 and current cross sections of the line in scale 1:200-1:100 step 50 m will be produced, indicating the existing and future geometrical parameters of the line.
2A	Demolition of line.	It consists in dismantling the existing worn out permanent way (rails, junctions, sleepers and fastenings), transportation of the materials to the deposit sites, dividing them into old and re-usable materials (residual value). This operation will be presumably carried out according to the methodology developed in this area: after having manually eliminated the fish-plated junctions of the rails, the dismantling train will pass over the free track panels, and its tail equipped with a dismantling crane will dismantle the track panels and automatically transport them into the front platform wagons.
3A	Excavation.	After having dismantled the permanent way, excavation of about 50-60 cm of topping material of the embankment by means of machine (bulldozer with front shovel). Generally, during this process, old polluted ballast and old polluted sub-ballast (sandy gravel) are discharged on embankment side for their future re-use. In case this work takes place into stations, the removed top material will be transported to dump. This item also include the further compaction of the top layer of the embankment for increasing hits bearing capacity and for re-shaping the embankment roof.

Module B – Detailed Design and Tender Documents of the rehabilitation measures for the Lugovaya – Kyrgyz Border railway section (Kazakhstan)

4A	Partial lateral rebuilding embankment section, placing and compacting the removed top material for widening the top surface of about 1,0 m on both sides.	This item will be applied only on those sections where the existing embankment is found to be eroded and not compliant with the typical cross section. In many cases in fact, ballast is falling on the embankment side for the embankment is reduced in transversal dimensions due to the water and wind erosion of hits slopes, not protected by means of grassing. For this item, material will be taken from the side material demolished in Item 3A for those sections where 3A took place, while for the other sections material will be transported or taken from the surrounding environment after tests. In order to widen the embankment side, the existing eroded side will be shaped in steps, and the additional earth will be added in layers of max 20-30cm in order to compact it by means of manual vibro-compacting machine.
5A	Implementation of a layer of sandy gravel material, 0,2 m thick under sleepers (sub-ballast).	After the item 4A, on the compacted top layer of the embankment the new layer of sandy gravel (sub-ballast) will be laid and compacted in the correct shape, according to typical cross section.
6A	Construction of line.	After the item 5A, the new track will be built (sleepers, fastenings and rails), by laying it on the sub-ballast layer. This procedure will be presumably carried out with the system used in this area, described in detail in the Figure on the next page. This system is based on the use of construction train, similar to the dismantling train, with opposed operations. Tail locomotive of this train will push the front laying crane against the section to be built, and the crane will lay track panels, casted outside of the field, on the sub-ballast layer. Provisional junctions will be installed and the construction train will run on the just installed panels. Construction of the line can also be carried out with other methods, as for example that envisaging the use of long welded rail to be laid on the two sides of the existing permanent way and the transportation of the sleepers only on the construction train. This second method allows to avoid the big number of weldings to be done on field and allows to transport on field sleepers and long rails separately. The first train transporting long rails would also run during line operation, laying the new rails on the two sides, the second train would dismantle the existing permanent way, cleaning and re-laying the sub-ballast, laying the sleepers (transported by its wagons) at the correct distance and it would finally install the lateral new rails on the sleepers, with fastenings. In the next pages the two envisaged construction methodologies will be described with schematic drawings. The item 6A also includes first layers ballast spreading, tamping and lifting of rails up to 3 cm to final level.
7A	Flash-butt or thermic weld of P65 rail.	Welding of the panels by means of flash-butt or thermic system. Welding of the rails will have to be done according to strict technical specifications, that will be detailed in the next phase of the study.
8A	Regulation of mechanical tension of long welded rails (l.w.r.).	After the rail welding, mechanical tensions will be regulated, according to strict technical specifications, that will be detailed in the next phase of the study.
9A	Final tamping and levelling of new line.	The permanent way, so welded and regulated, will be in this phase taken to its final level and alignment by means of final tamping and levelling.
13A	Excavation of ditches.	Hydraulic drainages must be cleaned and embankment side ditches must be excavated when absent, in order to protect the embankment side from water infiltration and foot erosion. In general, no concrete cover is requested for the ditches. Trapezoid ditch 0.5-0.5-0.5 has a volume of 0,5m ³ /m.

14A	Pavement of level crossings.	This item concerns the reconstruction of the pavement of the level crossings for the area of railway crossing only. It has been estimated that each level crossing envisages an area of about 50m by 10m.
20A	Replacing (or installation) of switch small tg (complete).	It includes dismantling of existing old turnouts and construction of new turnouts.

Several works are standard works which don't need to be detailed more than what has been described in the Technical Specifications included in the Tender Documents for the present Lot 4.1 (Annex A).

The Consultant has deemed important to detail more some specific methodologies for the implementation possibly introducing European methodology or comparing European methodology with the CIS methodology.

4.1 Methodology for the line construction (Permanent Way)

4.1.1 Methodology 1

Hereafter the procedure commonly used in Europe to implement these works with heavy machines is described (see also Figure 4.4.1-1 in the following page).

Previous activities

- I. the P65 rail bars 25 m long are welded in bars of 100+125 m and staked,
- II. the long P65 rail bars are loaded on platforms, transported and laid down along the line on both sides of the existing track, positioned and jointed to be initially used as service track for portal cranes,

Figure 4.1.1-1

METHODOLOGY 1 FOR TRACK REPLACEMENT

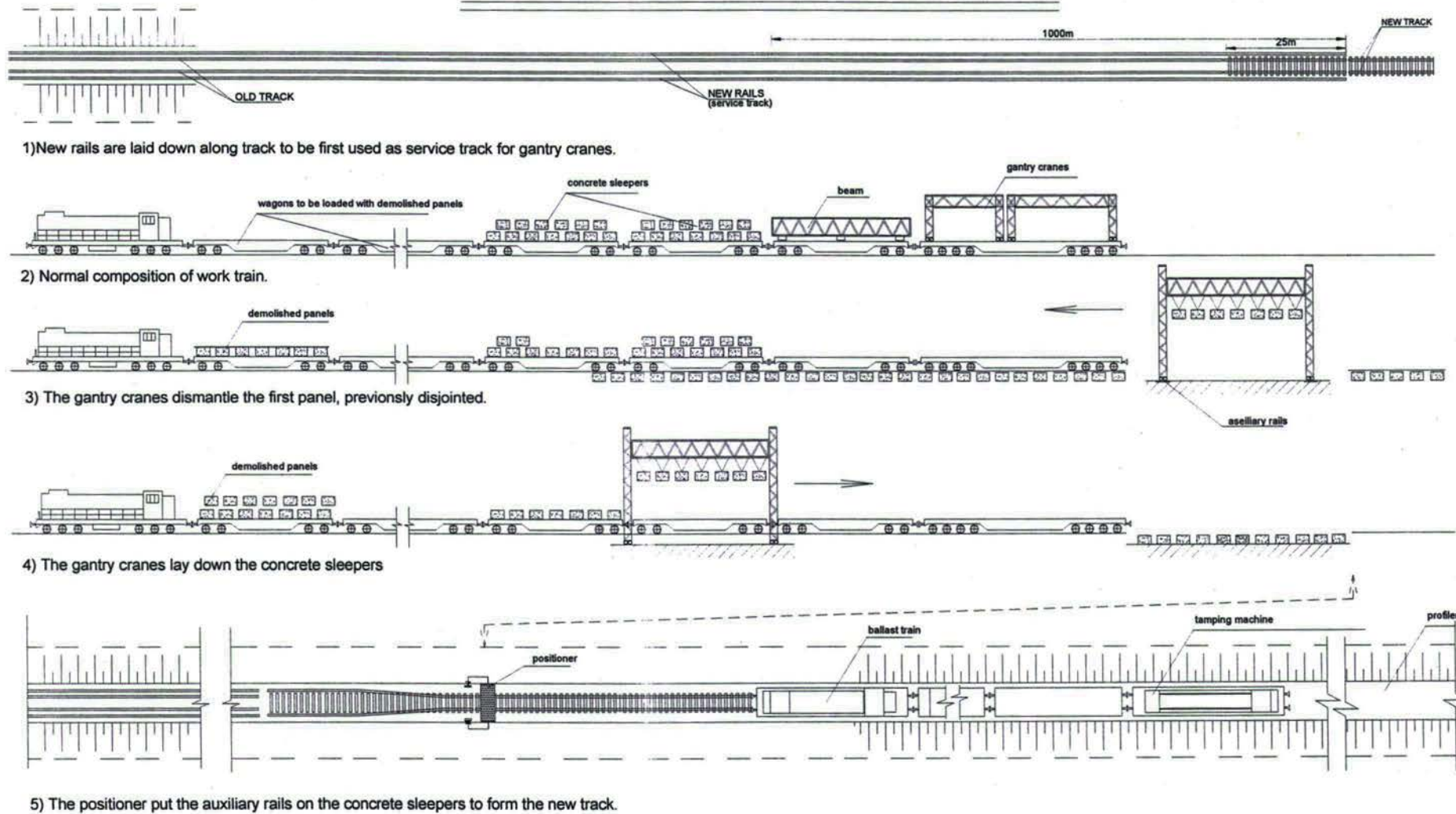

Activities to be done in the same day

- III. a work train arrive at the beginning of the stretch scheduled to be dismantled and rebuilt with P65 rails on concrete sleepers (in this case the average length of this stretch is 600 m per day). The work train is formed by:
 - o platforms loaded with 2 self moving portal cranes and an ancillary beam;
 - o platforms to be loaded by dismantled 25 m track frames;
 - o platforms loaded with concrete sleepers to be installed.
- IV. the portal cranes and ancillary beam, unloaded from the platforms, displace themselves on the service track, stop in correspondence of the first 25 m panel, previously disjoined from the adjacent ones, lift it and, coming back along the train, unload it on a flat wagon; this operations are repeated up to complete the dismantling of the scheduled length of track (see also item 2A);
- V. the excavation of the existing materials start and go on until the design depth is reached (see also item 3A);
- VI. the sandy-gravel material is spread on the surface between the service rails and compacted (see also item 5A);
- VII. the portal cranes by means of the ancillary beam lift the concrete sleepers from wagons, run along the service track and lay down in two phases the concrete sleepers on the sandy gravel layer (distance between sleeper axles = 0,54 cm, that is 1840 sleepers per km are to be laid down) up to cover the full length of the dismantled stretch; at this stage the Contractor shall make use of reference stakes for locating the track CL and avoid abnormal adjustments in a further stage;
- VIII. the portal cranes and beam are re-loaded on their wagons,

After placing the polyethylene pads on the rail seats of the sleepers, using a little machine called "positioner" the P65 rails, forming the service track till the present phase, are put in their definitive position on the concrete sleepers and fastened; at this stage 50% of fastenings will be inserted, the joints shall be assured with additional bolts.

The new track shall be, manually and/or using the tamping machine, leveled, aligned and put in order to allow the passage of trains at a temporary speed limit of 10 km/h,

Activities to be done in the following period

- IX. The long bars are welded up to a length of 400 m (temporary section); the Contractor may weld the joints by "thermit" or flash-butt process,
- X. the finishing of the excavation and of the sandy gravel layer on both external sides is implemented,
- XI. about 1 m³ of ballast is laid down and the track lift of about 0,20 cm using the tamping machine and jacks,
- XII. additional quantities of ballast are laid down and the track is lift up to reach a level of 0+20 mm to the design level,
- XIII. during the lay down of additional ballast, the lifting and tamping operation, the ballast section profile shall be adjusted by a "profiler" machine, equipped with a brush for clearing the track,
- XIV. before final lifting, straightening and leveling of the track, the Contractor shall carry out the regulation of the mechanical stresses of the rails, the formation of the continuous welded rails (CWR), adjust the expansion joints and fix the 100% of the fastenings.
- XV. a final tamping of the complete track has to be carried out, making use of an heavy tamping machine, at least 60 days after all the works described in the above paragraphs have been successfully completed. The final line profiling has also to be implemented at this stage.

4.1.2 Methodology 2

Hereafter the procedure commonly used in CIS countries to implement these works with heavy machines is described (Figure 4.1.2-1, Figure 4.1.2-2, Table 4.1.2-1):

Fig 4.1.2 – 1 Main work schedule in the major repair works on track

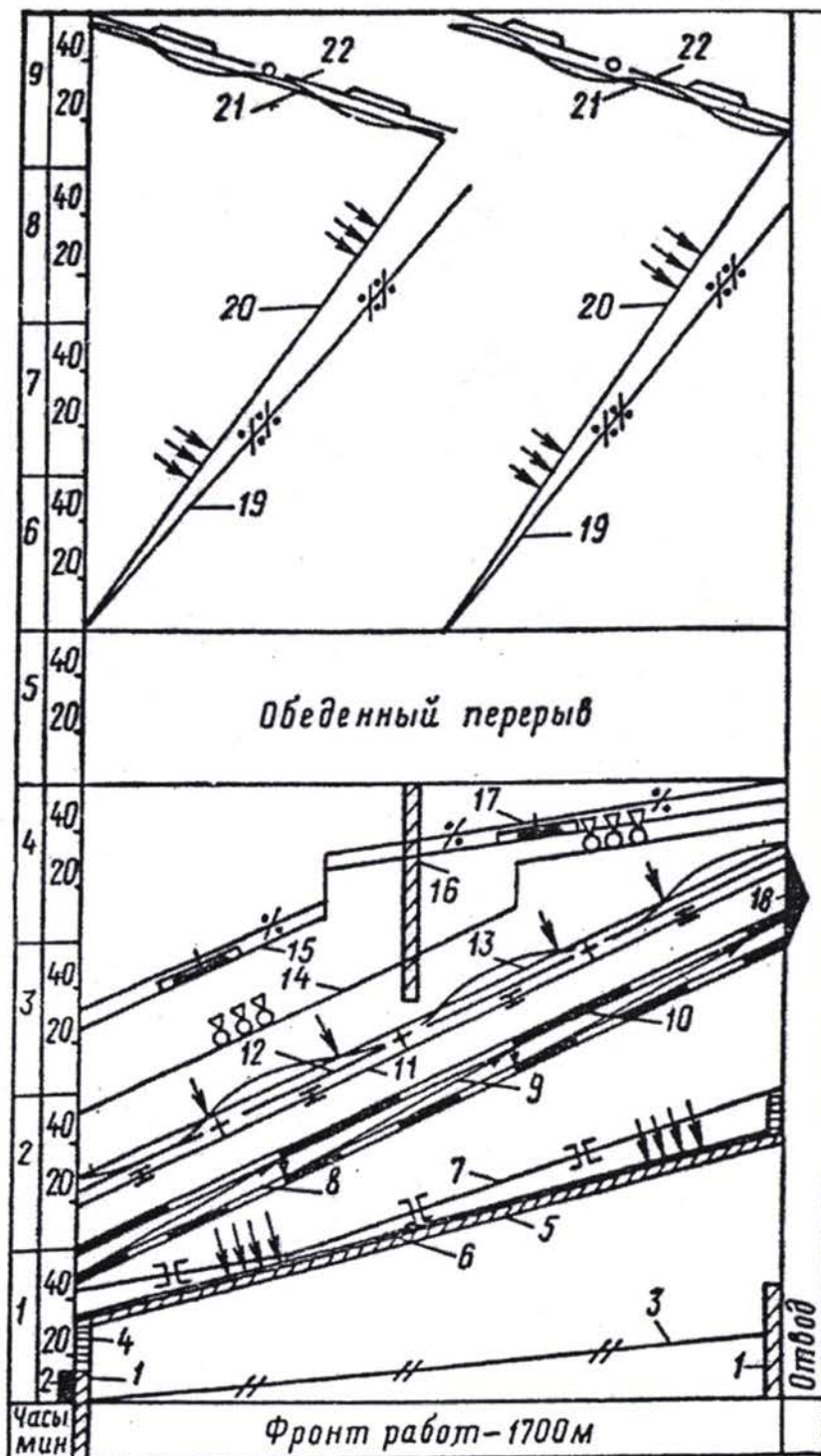

1 – preparing for charging and discharging of gravel-cleaning machine; 2 – securing the closure of the route section; 3 – preparing for dismantling; 4 - preparing for charging and discharging of gravel-cleaning machine; 5 – gravel cleaning; 6 – track rectification; 7 – unbolting the rail joints; 8 - dismantling of the track; 9 – gravel

Module B – Detailed Design and Tender Documents of the rehabilitation measures for the Lugovaya – Kyrgyz Border railway section (Kazakhstan)

ploughing; 10 – track laying; 11 - bolting the rail joints; 12 – installing inventory stop brakes; 13 – setting the track on axle; 14 – gravel unloading; 15 – track rectification with VPO-3000 machine; 16 – equipping electrically-failed joints; 17 and 19 – exit of stop brakes; 18 – exhaust unit; 20 - track rectification; 21 - lining of the track; 22 – prism alignment.

Finally, the following table contains detailed timing of each phase of the works.

Table 4.1.2 – 1 Operational main work schedule in "possession"

N.	Operation name	Planned time	
		Duration (min)	End of operation, Hours and minutes
	The passing of the last scheduled train on station		10.40
	<i>The work of the dismantling train</i>		
1	Arrival to the place of work	15	10.50
2	Positioning in running order	8	10.58
3	Dismantling of first packet (gravel-cleaning machine's work start)	12	11.10
4	Dismantling of second packet	12	11.22
5	Same, third etc	12	11.34
22	Dismantling of twentieth packet	12	14.58
23	Positioning in transport order	12	15.10
24	Departure of dismantling train	5	15.15
	<i>Gravel-cleaning machine's work</i>		
1	Arrival on track	5	11.15
2	Gravel cleaning on the first section extending over 50 m (beginning of track laying)	5	11.20
3	Finishing gravel cleaning	225	15.00
4	Derailment	5	15.05
	<i>Laying train work starts</i>		
1	Following to the place of work	20	11.10
2	Positioning in running order (start of laying)	10	11.20
3	First packet laying	12	11.32
4	Same, second etc	12	11.44
22	Twentieth packet laying	12	15.20
23	Exhaust unit positioning of crane in transport order	10	15.30
24	Departure for station	3	15.33
	<i>Hoppers-dozers work</i>		
1	Following to the place of work of welded structure from 40 hoppers-dozers (start unloading)	15	13.00
2	Ballast unloading during track laying		15.20
3	Unloading after track laying		15.35
4	Departure of welded structure from 40 hoppers-dozers for station		15.40
	<i>The work of VPO-3000 machine</i>		
1	Following to the place of work	15	13.35
2	Charging	5	13.40
3	Machine's work during gravel unloading		15.40
4	The finishing of the measured shovel-packing		15.55
5	Machine discharging and leaving for station	5	16.00
	<i>Hoppers-dozers work</i>		
1	Following to the place of work	15	14.00
2	Ballast unloading		16.15
3	Departure of welded structure from 40 hoppers-dozers for station		16.20
4	Time route section is closed	from 10. 40 until 16.40	

Fig. 4.1.2 – 2 Current Permanent Way replacement cycle

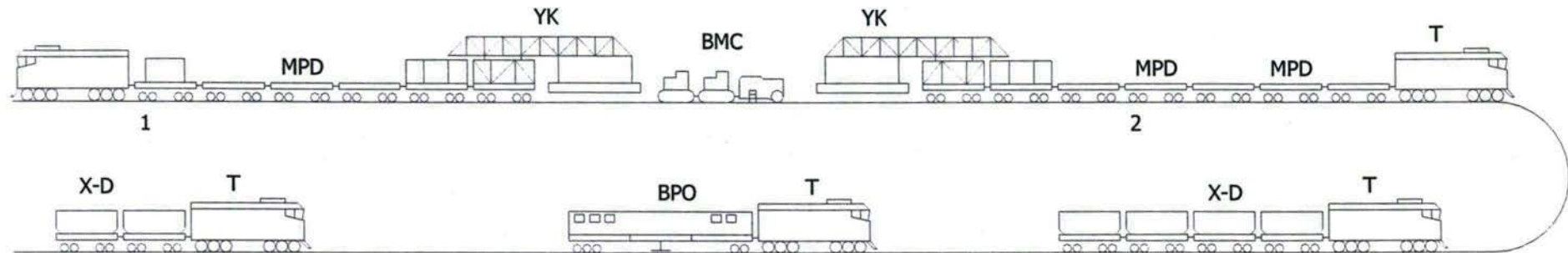

1 - dismantling (distributor) train; 2 - packing (laying) train; T - diesel locomotive;
MPD - motor platform; YK - laying crane; BMC - balast dearer; XD - hopper-batcher;
BPO - liner-tamper supfaser.

Previous activities

- I. panels 25 meters long of concrete sleepers fastened to P65 rails are prepared in a station near the work site and loaded on the laying train,
- II. a dismantling train and a laying train (loaded with the new panels to be installed), coming from one of the adjacent stations, are placed astride the first panel to be dismantled; every train has a crane on the queue of the composition, able to work on the site of this panel,
- III. the crane of the dismantling train lifts the first panel, whose joints have been previously unbolted, and, with a backward movement, lays it on a mobile device under crane on the platform wagon; this operation is repeated according to the possibilities given by the height of the crane, after a train displacing in successive positions correspondent to the other panels to be dismantled,
- IV. the mobile device, pulled by the rope of a winch, transfer on rollers the panels stacked on it to wagons in a rear position to allow the dismantling and stacking of more panels,
- V. on the dismantled stretch, excavation works start, using ballast cleaner machine, soil moving machines, motor grader, pneumatic-tired roller, leveler, to prepare the new sandy-gravel layer, if it is foreseen by the design, and /or a leveled ballast surface,
- VI. the crane of laying train, lays down the 25 m long new panels assembled P65 rails fastened on concrete sleepers, and provisional joints of panels are performed,

Activities to be done in the following period:

- VII. new ballast is spread along the line and the tamping machine start to compact ballast and to lift the rails up to 2+3 cm from the design level,
- VIII. rails are welded in 800 m bars and provisional joints recovered,
- IX. during the lay down of additional ballast, the lifting and tamping operation, the ballast section profile shall be adjusted by a “profiler” machine, equipped with a brush for clearing the track,
- X. before final lifting, straightening and leveling of the track, the Contractor shall carry out the regulation of the mechanical stresses of the rails, the formation of the continuous welded rails (CWR), adjust the expansion joints and fix the 100% of the fastenings.
- XI. a final tamping of the complete track has to be carried out, making use of an heavy tamping machine, at least 60 days after all the works described in the above paragraphs have been successfully completed. The final line profiling has also to be implemented at this stage.

4.2 Methodology for rail welding

According to the information collected, the habit in CIS countries is not to weld rails on site but in the workshops. The length of the section to be considered is therefore limited by transport constraints (up to 800 m of long welded bars).

The European experience proves that rail welding can be performed on site by either of two methods:

- Thermic process
- Electric process

4.2.1 Thermic welding

Type - The thermic welds shall be of the “rapid” type with prefabricated moulds and oxygen activated preheating.

Material and Equipment – The moulds shall be of the prefabricated type and suitable for P65 rails; they shall be stored in the cardboard boxes in which supplied.

The welding portions shall be of the type suitable for welding, with normal welding gaps, P65 rails in workshop or on site.

They shall be packed in sealed bags bearing in print the characteristic data: type of weld (“rapid”), type of rails and of steel. It is not allowed to use welding portions whose packaging has been tampered with and nothing shall be empirically added to or removed with welding portions. Should it be found necessary, in particular cases recognized as inevitable by the Engineer, to weld with wider gaps than specified, use shall be made of the appropriate welding portions.

Pre-heating shall be done by means of a suitable oxy-propane burner.

Particular care shall be taken in the storage of materials; the welding portions and the moulds shall be stored in a dry room away from inflammable materials; the oxygen cylinders and propane bottles shall be stored in isolated rooms and apart from each other. The welding equipment may be stored in the room where the welding portions and moulds are stored.

Operating procedures – The gap between the rail ends to be welded shall be between 15 and 16 mm or as specified by the manufacturer of the welding portions.

The rail ends shall be perfectly aligned in both the horizontal and vertical plane. To compensate for lowering due to thermal contraction, the two rail end sections shall be raised by 1 mm. The alignment shall be maintained during welding by inserting steel wedges. The rail ends shall be cleaned with a wire brush and any moisture dried by using the burner.

The welding casting shall not be poured directly into the mould but through a casting pocket. The slag shall be collected in an appropriate box.

The burner shall be accurately centred on the welding gap and placed with the orifice 40 mm above the running surface of the rail.

During the pre-heating, the oxygen and propane pressures shall be respectively 5 kg/cm² and 0.5 kg/cm². the pre-heating shall last not less than 6 minutes.

The above data are indicative and compliance therewith shall not relieve the Contractor from responsibility for the correct execution of the welds.

The procedures for the subsequent operations, from the ignition of the portion through removal from the moulds, are left to the worker's experience and skill.

The feed head may be removed by hammer and chisel or by a hydraulic press fitted with a suitably shaped chisel. The chiseling operation shall not result in the removal of material from the essential part of the welds.

The side surfaces and the running surface of the rail head shall be ground down by means of a suitable grinder to the normal rail profile.

On the remaining parts of the rail section the presence of the weld bead remaining from the chiseling operation shall be tolerated, after removal of the feed head and of the other superfluous parts of the weld casting, the welded joint shall be cleaned with a wire brush and protected by rust-proofing paint over a length of 20 cm.

Sample Testing and Checking

- I. **Moulds:** visual inspection for integrity shall be performed on a 4% sample of each stock of welding moulds.
- II. **Portions:** two portions chosen by the Engineer shall be taken from each stock and two welds shall be executed on two pairs of rail sections, each 0,75 m long, so as to obtain two samples with a welded joint.
- III. **Bending test:** samples shall be subjected to the bending test in accordance with the following sketch:

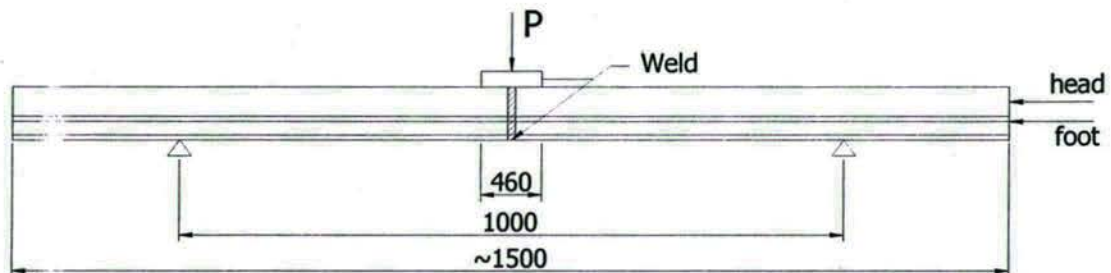

Load P shall be increased slowly from 0 to 40 tons, continuously recording the deflection of the mid portion. Under the maximum load neither cracks nor fractures shall appear. After removing the load, the residual permanent deformation shall be measured one hour after the test.

- IV. **Internal sections:** the specimen shall be cut through the center of the weld along a plane perpendicular to the longitudinal axis and then along the plane of symmetry of the rail sections. The sulphur print of the cross section shall be taken. Inspection of the sections shall show no cavities, internal damage or porosity. At the Engineer's absolute discretion, a light degree of porosity internally to the web and head may be tolerated.
- V. **Brinell hardness:** on the longitudinal section, 5 mm under the surface the hardness shall be measured over a 300 mm length. The Brinell hardness shall be comprised in the range of 20 units less to 40 units more than that measured on the steel of the original rail. The hardness test shall be performed with a steel ball 10 mm in diameter pressed against the steel with a load rising from 0 to 3000 dN in 30 second. The impression shall be spaced to 10 mm intervals.
- VI. **Other tests:** any other test required by the Engineer with a view to determine the quality of the material used for thermic welding may be carried out. In the event of failure the weld shall be rejected.

Manufacture Checks and Tests

Each stock of welding portion supplied shall be accompanied by a certificate issued by an official testing Institute of the manufacturer's country, showing the results of the following tests performed on rail section welded with one of the portions from the stock, following the same procedures above outlined:

- bending test (see the preceding III. Paragraph)
- Brinell hardness (see the preceding IV. Paragraph)
- Sulfur prints of the weld cross section, and
- Chemical analysis which shall show that S and P contents not exceed each 0.05% and combined 0.09%.

Systematic Weld Checks

The following checks shall be performed on the welds executed in workshop or on the line:

- **Visual check** - A perfectly straight ruler 1,0 m long, accurate to within 1/10 of 1mm, has to be used for lining and leveling the welded joint; the check shall be done over a length of 1 m

centered on the weld and defects shall not exceed those shown in the drawing L1.4-15 of the annexed Tender Documents,

- Visual check for the integrity of the weld,
- Ultrasound check by means of a special apparatus operating above the 3 MHz frequency

4.2.2 Electric Flash-butt Welding

Rail welding machine

The welds are executed by a welding machine that may operate either on track along the line or in the station yard.

The welding head shall be suitable for welding P65 rails and perform the following functions:

- grabbing the rail ends over a sufficient length to ensure good alignment and hold them tightened with great force for the entire duration of the process,
- heating the rail ends and bringing them to the upsetting state,
- upset-welding the rail ends with the necessary force,
- allowing the mechanical removal of the welding bead,
- leaving the rail with the joint in good alignment and condition.

All the welding process shall take place automatically without the intervention of the operators whose only jobs shall be to prepare the rails, remove the welding beads and finish the rail head surface.

After the mechanical removal of the bead produced by upsetting the head surfaces shall be finish-ground with a grinding machine, as required for the thermic welds.

For the acceptance of the welds the welding machine shall be equipped with a special apparatus recording the following data for any weld:

- current absorption,
- shortening of rails due to metal fusion,
- the battering force of the welding head.

Should the recording apparatus be out of order, no welding work will be allowed.

Sample Checking and Testing

Before beginning work, The Contractor shall prepare two sample welded joints produced with the welding machine which he plans to use. The samples shall have the same characteristics as those prepared by thermic welding and shall be subjected to the following checks and tests:

- visual check with 1 m metal ruler of the same characteristics as that used to check thermic welds,
- bending test as that used to check thermic welds,
- internal sections as that used to check thermic welds,
- Brinell hardness check as that used to check thermic welds.

The machine shall be accepted if the result of the tests and checks prove satisfactory and conform with the specifications. Otherwise the Contractor shall adjust the machine and repeat the tests until satisfactory results are obtained. Should the Contractor fail to obtain results conforming with the specifications, the machine shall be rejected.

Systematic Weld Checks and Tests

Every flash-butt weld is subjected to:

- a. visual checks as that described for thermic welds;
- b. integrity check.

4.2.3 Formation of Continuous Welded Rails (CWR)

The purpose of forming CWR is to eliminate all rail joints and creating in the rails an even condition of thermal stresses in order to prevent thermal expansion (stress settling). The temperature at which the CWR is formed is called **neutral temperature** (zero stress at all points of the rail), hereinafter abbreviate as NT.

No CWR shall be formed on curves with a radius lower than 350 m and in stations where they will be formed according to Engineer's instructions.

On the lines equipped with Automatic Block, the CWR is to be interrupted in correspondence of the signals and an insulated joint has to be installed to allow the correct work of the track circuits; towards and backwards two stretches 12,5 m long have to be formed using by means of two additional normal joints.

The CWR shall be formed at the NT. The conditions required to get the NT may be obtained either naturally or artificially, i.e. by natural heating or with the use of tensors.

The temperature of the rail shall be monitored for at least one year and the NT lies in the range of $+ 7^{\circ}\text{C} - 3^{\circ}\text{C}$ of the average temperature. The NT shall be fixed by the Engineer at the beginning of work.

The Contractor shall be required to have available special rail thermometers suitable for measuring rail temperatures to within 1°C .

The forming of the CWR shall be done on days when the rail reaches the NT by natural Heating and the NT is likely to remain constant within $\pm 3^{\circ}\text{C}$ through the entire duration of the forming operation. If these conditions are not obtained, the operations shall be suspended.

In a temporary section (see paragraph IX. of the item 6A Construction of line), the 36 m long central zones are defined as **central stretches** (CS).

The CWR is formed by welding two contiguous temporary semi-sections, through the following operations:

- I. disassembling the fastenings on all sleepers, except in the CS zones of the contiguous temporary semi-sections,
- II. disassembling the temporary joint between the two temporary semi-sections,
- III. lifting the rail by means of stakes, starting from the joint towards the CS and inserting every 9 m expansion rollers into the rail seats, after removing the polyethylene pads; the expansion rollers, at least 20 mm in diameter, shall be positioned with their axles perpendicularly to the rail,
- IV. jarring the rail with wooden mallet blows to facilitate its expansion and the removal of any hindrances to thermal expansion,
- V. cutting thin slices off the rail ends to allow the free expansion of the temporary semi-section; this is necessary when the forming of the latter was done at temperatures below the NT. In the event of the temporary semi-sections having been formed at temperatures higher than the NT, a makeup rail shall be inserted to fill the gap due to thermal contraction. The length of the makeup rail shall be not less than 3 m. The makeup rail shall be welded to either of the temporary sections ends,

- VI. having reached the NT within ± 3 °C, forming the welded gaps, forming the weld gaps, quickly removing the expansion roller (starting from the CS), reinstalling the previously removed polyethylene pads,
- VII. assembling the fastenings, starting to the joint towards the CS, of the first 40 sleepers and next of one sleeper every three,
- VIII. welding the joint,
- IX. during the welding, completing the assembling of the fastenings,
- X. immediately on completion of the casting of the thermic weld, disassembling the fastenings of 46 sleepers astraddle the joint in order to allow the thermal contraction of the weld on a rail length of at least 12 m on each side,
- XI. after one hour, assembling the fastenings disassembled in step X.

Rail pulling

When it proves impossible to form the CWR by natural heating, the use of rail tensor may be required.

The tensors shall be designed to permit the execution of thermic welds and be able of producing a 60 t pull without damaging the rails.

Stress settling and CWR forming shall not be allowed to be done at temperatures under + 10 °C.

When rail pulling is used, the following operations shall be carried out, after applying the rail thermometers to the rails:

- 1. same as per point I,
- 2. same as per point II,
- 3. same as per point III,
- 4. same as per point IV,
- 5. affixing a reference mark on the rail foot on the ends of the two temporary semi-sections, recording the rail temperature, calculating the elongation to be produced in the two temporary semi-sections, multiplying 0,000012 by the length of the two temporary semi-sections and by the difference between the NT and the temperature recorded on the rail,
- 6. applying the turnbuckles and pulling the rails till the calculated elongation is achieved, as checked by reference marks, jarring the rails by wood mallet blows to facilitate elongation and remove any interferences therewith,
- 7. cutting thin slices off the rails ends to allow elongation,
- 8. when the calculated elongation is reached, quickly removing the expansion rollers starting from the CS and reassembling the rubber pads,
- 9. assembling the fastenings, starting from the joint towards the CS,
- 10. welding the joint, continuing to pull the rail till 3 minutes after the casting of the thermic weld to compensate for the tension stress of weld contraction during weld solidification,
- 11. loosening and removing the turnbuckles 10 minutes after the casting of the weld,
- 12. disassembling and immediately reassembling the fastenings of 46 sleepers astraddle the weld

4.3 Bill of quantities

Consideration derived by the adoption of the above technologies together with more standards consideration brings to the assessment of the following bill of quantities which considers both works and materials.

Table 2.2-2 – Bill of quantities for the permanent way and civil works

Code	Description	Unit	Quantity	Notes
A. WORKS				
1A	Topographic survey of the line and corrections of the existing alignment and profile	km	61,00	All the line, including stations.
2A	Demolition of line	km	60,50	All the line is equipped with P65 rails on wooden sleepers and Merke station equipped with P50 rails. It has been excluded the total length of switches (about 0,5 km)
3A	Excavation	m ³	172691,20	It includes the removal of about 0.6 m tick layer of top embankment material (ballast and sub-ballast), laying it on both sides of the embankment, profiling and compacting the top section of the embankment.
4A	Partial lateral rebuilding embankment section for 100 km, placing and compacting the removed top material for widening the top surface of about 1,0 m	m ³	81450,00	It includes control and correction of 3.A material granulometry, if necessary, placing and compacting the removed top material for widening the top surface of about 1,0 m. In case the embankment is 1,0m high, it consists in removing 0,15m ³ /m and adding 1m ³ /m, in case the embankment is 2,0m high, it consists of removing 0,30m ³ /m and adding 2m ³ /m. It has been considered for a line length of 15 km.
5A	Implementation of a layer of sandy gravel material, 0,2 m thick under sleepers (sub-ballast)	m ³	65485,20	It includes spreading, compacting and profiling section of materials.
6A	Construction of line	m	60500,00	It includes installation of concrete sleepers, P65 rails, fastenings, spread of ballast, tamping and lift of rails up to 3 cm to final level.
7A	Flash-butt or thermic weld of P65 rail	unit	4330,00	(61 km)x2/25 less joints (as calculated in 13B and 14B).
8A	Regulation of mechanical tension of long welded rails (l.w.r.)	km	121,00	(60.5 km)*2.
9A	Final tamping and leveling of new line	km	61,00	Switches included.
13A	Excavation of ditches	m of line	5200,00	Longitudinal ditches in stations.
14A	Pavement of level crossings	unit	10,00	Each level crossing envisages an area of 50m by 10m.
20A	Replacing (or installation) of switch small tg (complete)	unit	1,00	Installation of 1 new P65 turnouts including the demolition of the existing P50 tg 1:11 one in Merke station.

B. MATERIALS				
1B	P65 rails	t	1430,00	One km of new rails for Merke running track plus about 10 km of new rails for replacing the necessary sections of re-used P65 rails.
2B	Concrete sleepers	unit	115000,00	minimum 61km * 1840 = 112240
3B	Fastenings for concrete sleepers	pairs	115000,00	
4B	Ballast for renovated sections	m ³	107206,00	1,77 m ³ /m on straight (98%); 1,9034 m ³ /m on curve (2%) (cantilever: 75 mm).
6B	Sandy gravel on track sections (new sub-ballast layer)	m ³	65485,20	1,08 m ³ /m on straight; 1,2 m ³ /m on curve.
7B	Blocks for level crossings	unit	240,00	0,24 m ³ each block. 24 blocks per L.C. Cement price 190,0 US\$/m ³
12B	Switch complete (small tg)	unit	1,00	One P50 turnout to be replaced in the Merke station
13B	Rail Joints	each	440,00	4 joints for each insulated joints
14B	Insulated rail joints	each	110,00	Minimum 51*2 insulated joints for track circuits (the line section is divided in 51 block sections)
18B	Concrete ditch (pipe) for station main track drainage.	m	5000,00	It includes poor concrete bed and different layers of gravels for drainage. 5 km for all stations main tracks.

4.4 Costs estimates

4.4.1 Unit costs

For the rehabilitation of the Lugovaya – Kyrgyz border section, a detailed cost analysis has been carried out by this Consultant.

In order to achieve reliable figures for manpower and materials costs, Italferr carried out a cost analysis both in Kazakhstan and in Kyrgyzstan, for comparing and grouping in the best way the unit costs. But, taking into consideration that the works have been assumed to be carried out by the Kazakh Railways Administration, according to the information for which this railway section will be presumably operated and maintained by Kazakhstan after 2007, the Consultant decided to adopt Kazakh figures.

For not available figures, the Consultant carried out its own investigations and reached reliable figures for the purpose of the project.

The analysis was aimed at detailing all the cost items, including foreign and national expenditures for materials, foreign and national cost for man-power, cost of the machines (purchase costs) and expenditures for taxes, duties and Contractor and Client general expenditures.

For the Infrastructure, the construction cost is subdivided into the following types of work and expenditures in accordance with the structure of capital investments and the planned schedule of activities of constructing-and-mounting companies (Contractors):

- Materials;
- Construction works;
- Miscellaneous expenditures of a contractor;
- Miscellaneous expenditures of a customer.

A Contractor includes in the above cost both direct and concomitant expenditures (factor costs, miscellaneous expenditures, profit, and also funds for payment of taxes, duties and other obligatory payments).

Direct expenditures (including miscellaneous ones) are the expenditures of a Contractor to construct a requested object that is labour and material resources, etc.

When calculating a construction cost, the following types of work and expenditures are considered:

1. Materials cost – cost of the necessary building materials, divided in national and foreign costs, according to the production Country;
2. Manpower Construction works – works on construction of buildings, different types of structures, finishing works, installation of external and internal engineering networks, installation of foundation and supporting structures for equipment, preparation a site for construction, etc.;
3. Manpower Mounting works - assembly and installation of devices at the place of their permanent operation (including inspection and individual testing of all kinds of equipment, electric installations, devices, computer engineering, connection of the equipment to engineering networks and other works);
4. Miscellaneous expenditures are the rest of expenditures not included in the factor costs for construction-and-mounting works, including:
 - Other industrial expenditures defined for a construction project (a contractor's expenditures);
 - For organization of construction works (overhead expenses);
 - For construction of temporary buildings;
 - For performing works in winter time;
 - For long service bonus;
 - For additional leave of workers;
 - Traveling expenses;
 - For transportation of workers up to the building object;
 - For relocation of construction-and-mounting organizations;
 - For a mobile method of work performance;
 - Insurance of construction risks;
 - Obligatory payments (taxes), duties in conformity with the local legislation;
 - Unforeseen costs and other expenditures for construction of objects.

Besides, the construction cost includes other expenditures of a customer during the construction:

- Allotment of a piece of land for construction of an object and external engineering structures;
- Fixing of points and signs;
- Demolition of structures;
- Bonus for timely and prescheduled commissioning of objects;
- Insurance of building risks;
- For banking services;
- Loan interests;

- Maintenance of a customer's facilities;
- Training of operational staff;
- Design and survey works;
- Survey works;
- Expertise of the design documentation;
- Profit necessary to cover the expenditures of a customer;
- Unforeseen costs.

The cost of the above mentioned expenditures is defined through calculations or through actual expenses of a customer and a contractor.

In the conditions of the market economy being developed in Kazakhstan, the prioritized importance is attached to the method of calculating a construction cost based on the cost of resources. This method of defining a construction cost is a method of calculating expenditures in current prices or forecast prices and tariffs to be incurred during a project implementation.

A construction cost in current prices is defined on the basis of resource estimates developed through the above mentioned resource method with the use of information on actual prices for resources.

The factor cost is determined based on the allocated resources in current prices by types of expenditures:

- a) wages including charges on social insurance;
- b) maintenance cost of machines and mechanisms;
- c) cost of building materials, items and structures including their transportation.

4.4.2 Unit costs for materials

The following table resumes the main unit costs for materials, according to detailed investigation carried out over the Kazakh and international market, split into "foreign" or "national production.

Table 4.4.2 – 1 Main unit costs for materials

<i>Rehabilitation works for Lugovaya - Balykchi Line - Lugovaya-Kyrgyz Border section</i>				
<i>"Main unit costs for materials"</i>				
Material	Unit	Rate (\$)	Variation	
Rails	tonne	580.00	+/-20\$	Foreign
Concrete sleepers	each	25.00	+/-4\$	National
Indirect fastenings	couple	25.00	+/-3\$	Foreign
Ballast	m3	5.50	+/-1\$	National
Sub-ballast	m3	2.00	+/-1\$	National
Total turnout large tangent with concrete sleepers	each	43,000.00	+/-10%	Foreign
Total turnout small tangent with concrete sleepers	each	52,000.00	+/-10%	Foreign
Rail joint	each	25.00	+/-4\$	Foreign
Isulated joint	each	34.00	+/-4\$	Foreign

4.4.3 Unit costs for machines

The following table resumes the main average unit costs for machines used for similar rehabilitation works for railways.

Table 4.4.3 - 1

<i>Rehabilitation works for Lugovaya - Balykchi Line - Lugovaya-Kyrgyz Border section</i>			
<i>"Main unit costs for machines"</i>			
	<i>Machine</i>	<i>Unit</i>	<i>\$</i>
1.	MOTORGRADERSE (MAINTAINERS) OF MEAN (AVERAGE) TYPE 99 [135] KWT [Л.С]	MACH/HOUR	8.27
2.	BULLDOZER AT WORK ON OTHER TYPES OF CONSTRUCTION: 79 [108] KWT [Л.С]	MACH/HOUR	11.63
3.	BULLDOZER AT WRK ON OTHER TYPES OF CONSRUCTION: 96 [130] KWT [Л.С]	MACH/HOUR	11.63
4.	TROLLEY OF WIDE GAUGE WITH CRANE 3,5 T	MACH/HOUR	17.69
5.	GANTRIES OVERHANGING FOR WORKS ON ASSEMBLAGE BASES, 10 T	MACH/HOUR	2.02
6.	CRANES ON RAILWAY MOTION 16 T	MACH/HOUR	8.27
7.	STACKING (LAYING) CRANES FOR RAIL UNITS 25 M ON WOODEN SLEEPERS	MACH/HOUR	67.71
8.	STACKING CRANES FOR RAIL UNITS 25 M ON CONCRETE SLEEPERS	MACH/HOUR	67.71
9.	MACHINES FOR BALLASTING OF RAILWAY TRAIL ON CONCRETE SLEEPERS	MACH/HOUR	37.24
10.	MACHINES FOR TAMPING WITH PNEUMATIC TAMPING PICK (CUTTING)	MACH/HOUR	12.16
11.	LINERS	MACH/HOUR	3.11
12.	MOTOR PLATFORMS FOR TRACKLAYER	MACH/HOUR	37.58
13.	PLATFORM OF WIDE GAUGE WITH ROLLER CONVEYER	MACH/HOUR	2.41
14.	PLATFORMS OF WIDE GAUGE 71 T	MACH/HOUR	2.41
15.	SELF-PROPELLED TRACK LIFT	MACH/HOUR	6.11
16.	DIESEL LOCOMOTIVES OF WIDE GAUGE SHUNTING 883 [1200] Kwt [Л.С]	MACH/HOUR	59.47
17.	DIESEL LOCOMOTIVES OF WIDE GAUGE 294 [400] KWT [Л.С]	MACH/HOUR	59.47
18.	SINGLE BUCKET DIESEL EXCAVATOR ON CATERPILLAR AT WORK ON OTHER TYPES OF CONSTRUCTION: 0,4 M3	MACH/HOUR	14.06

These figures are referred to Railway Administration (R.A.) owned machines. It is therefore assumed that the Contractor will make use of these machines, by renting them from the R.A. or will use its own machines at similar current costs.

Anyway, for the work typology considered in the frame of the line rehabilitation, this Consultant estimates that the cost of machines is between 6 and 10% of the materials cost.

4.4.4 Unit costs for local manpower

It is assumed by this Consultant that the works to be carried out for the line rehabilitation will be carried out by local manpower with the exception of field engineers and works coordinators, whose costs will be considered apart.

It is estimated therefore that the Contractor will make use of local workers and the average salaries and wages have been derived from those of railway employees in the country to which the line belongs (Kazakhstan).

The following table 4.4.4-2 resumes the main unit costs for local manpower, per work item, according to the bill of quantities adopted for Options evaluation and based on average worker cost data, shown in table 4.4.4-1.

Table 4.4.4 – 1 Average worker cost data

<i>Rehabilitation works for Lugovaya - Balykchi Line - Lugovaya-Kyrgyz Border section</i> <i>"Average worker cost data"</i>		
Average annual salary of builders in the region counting on 1 month, defined from statistical data for previous 12 months.	253.8	\$/ month
Average monthly fund of working time in hours	168	hour
Coefficient of account of the amount of deduction for social insurance (Kcc)	1.48	coeff.
Net local manpower cost per hour	1.511	\$/hour
Total local manpower cost per hour	2.236	\$/hour

Table 4.4.4 – 2 Main unit cost for local manpower

<i>Rehabilitation works for Lugovaya - Balykchi Line - Lugovaya-Kyrgyz Border section</i> <i>"Main unit costs for local manpower"</i>			
	Work Items	Unit	US\$
2A	Demolition of line	km	975.61
3A	Excavation	m ³	0.37
4A	Partial lateral rebuilding embankment section placing and compacting the removed top material for widening the top surface of about 1,0 m	m ³	0.49
5A	Implementation of a layer of sandy gravel material, 0,2 m thick under sleepers (sub-ballast)	m ³	0.07
6A	Construction of line	m	2.15
7A	Flash-butt or thermic weld of P65 rail	unit	4.00
8A	Regulation of mechanical tension of long welded rails (l.w.r.)	km	300.00
9A	Final tamping and leveling of line	km	316.41
10A	Ballast cleaning on the other existing sections	km	116.62

Module B – Detailed Design and Tender Documents of the rehabilitation measures for the Lugovaya – Kyrgyz Border railway section (Kazakhstan)

11A	Tamping, leveling and aligning the existing sections with l.w.r.	km	316.41
12A	Substitution of concrete pipes of 20 culverts	n	200.00
13A	Excavation of ditches	m	2.00
14A	Pavement of level crossings	unit	400.00
15A	Passenger stations: platforms new	m2	24.00
16A	Passenger stations: platforms restyling	m2	16.00
17A	Passenger stations: building restyling	m2	120.00
18A	Replacing switch crossings	unit	166.88
19A	Replacing switch blades	unit	166.88
20A	Replacing of switch small tg (complete)	unit	333.76

4.4.5 Cost calculation flow

The following Table 4.4.5-1 resumes the main factors for calculation of the total cost amounts.

Table 4.4.5 – 1 Main factors for calculation of total cost amounts

<i>Rehabilitation works for Lugovaya - Balykchi Line - Lugovaya-Kyrgyz Border section</i> <i>"General data for project cost estimation"</i>		
Expenses for operation of machines and mechanisms (Сэм)	5-10%	of materials cost
Transport expenditures for materials	6	%
Transport expenditures for constructions	6	%
Risk coefficient	1.15	coeff.
Other expenses and cost of contractor	20	%
Expenses for insurance of construction objects	0.4	%

Other expenses and costs of the contractor include:

- profit;
- administrative costs of the company;
- fix costs for the company;
- other general expenses.

The value of 20% has been recovered among average values of similar works in Kazakhstan.

The following table resumes the cost calculation flow.

Table 4.4.5 – 2 Cost calculation flow

Rehabilitation works for Lugovaya - Balykchi Line - Lugovaya-Kyrgyz Border section "Project cost calculation flow"		
Item	Article of expenses	Calculation method
A	Cost of construction + 6% transport	A
B	Other expenses and costs of the contractor	B=20%A
C	Total cost of construction and contractor and expenses	C=A+B
D	Tax 25%	D=25%C
E	Total cost of construction and contractor expenses with taxes	E=C+D
F	Expenses for insurance of construction objects	F=0,4%E
G	Risk coefficient defined on basis of forecasted index of construction price growth for the following year	G=15%(E+F)
T	Lot cost	T=E+F+G

The following table 4.4.5-2 resumes the result of cost analysis for the Lot 4.1 Permanent Way and Civil Works. It has been developed according to the detailed bill of quantities, the unit cost and the rationale above provided.

Table 4.4.5-2 Lot cost analysis

Rehabilitation works for Kungrad - Kazakh Border section "Lot 1.1 Permanent way and Civil Works"		
Item number	Article of expenses	Cost (\$)
A	Cost of construction + 6% transport	8.521.285,94
B	Other expenses and costs of the contractor	1.704.257,19
C	Total cost of construction and contractor expenses	10.225.543,13
D	tax 25%	2.556.385,71
E	Total cost of construction and contractor expenses with taxes	12.781.928,91
F	Expenses for insurance of construction objects	51.127,72
G	Risk coefficient defined on basis of forecasted index of construction price growth for the following year	1.924.958,49
H	Lot cost	14.758.015,12

5. Implementation schedule

The following Table 5 - 1 shows the implementation plan for the works envisaged for the Lot 4.1.

The scheduled activities will be completed in 26 months.

**Module B – Detailed Design and Tender Documents of the rehabilitation measures
 for the Lugovaya – Kyrgyz Border railway section (Kazakhstan)**

Table 5.1 Implementation programme

ACTIVITY/months		1	2	3	4	5	6	7	8	9	10	11	12	13	14	15	16	17	18	19	20	21	22	23	24	25	26
1	Approval of finacement	*																									
2	Final tender document preparation																										
3	Tendering and signing contract																										
4	Mobilization																										
5	Topographic survey, final profile																										
6	Provision of materials																										
7	Welding P65 rails in 100m bars																										
8	Laying down 100 m rail bars along the line																										
9	Demolition, excavation, laying down new subballast, ballast, concrete sleepers, P 65 rails																										
10	Dismantling, recovering P65 rails and other materials																										
11	First ballasting, first tamping																										
12	Second ballasting, second tamping																										
13	Welding rails in 1000m bars along the line																										
14	Regulation of rail mechanical tension and welding in long bars.																										
15	Final tamping, leveling, aligning																										
16	Tests and taking over of rehabilitated line																										

6. Tender Documents

6.1 Introduction

Purpose of this activity is “to prepare contract packages for international competitive bidding, international shopping, and direct purchase in accordance with standards development bank procedures”.

The scope of each package depends on the recommended solutions in the Feasibility Studies (FS). The following detailed design of the recommended improvement has given the input to the tender documents preparation.

Besides the technical recommended solutions, the procurement activities are deeply affected by standard development bank procedures. Despite a common philosophy, each bank normally has its own Guidelines for Procurement or a standard document to be adapted time by time.

On the other hands, the Consultant can't produce tender documents taking into consideration all factors deriving from all the possible combination among: several feasible packages and four (maybe more) standard documents (EBRD, ADB, IDB, World Bank, national).

All the above results in the following:

- each package has been prepared in accordance with requirements of the Guidelines of possible financing banks, which assure International Competitive Bidding;
- the Consultant can produce only a “draft tender document” since several details (for instance (i) tender Identification Number, (ii) Deadline for submission of the Tender, (iii) time, date and place of tender opening, (iv) date and location of pre-tender or site meeting, (v) Employer's address, etc.) are not known at the moment and will be known in the time being up to end of the project;
- several details are susceptible to be changed before the date of the tender publication.

6.2 The adopted philosophy for procurement

The Consultant has developed the philosophy for a successful procurement of the Package taking into consideration the following basic criteria.

The Standard Bidding Documents of Asian Development Bank (ADB) have been adopted.

It is noted that the Standard Bidding Documents adopted from various banks such as WB, EBRD, IDB, ADB, etc. slightly differs one each other.

In fact the above said banks have adopted since many years a policy of homogenization of the Tender Documents.

Such approach of using international standards leaves open the possibility of adopting guidelines of procurement of Institutions other than ADB.

Basically the legal relationships between the Borrower and the Bank are governed by the Loan Agreement. However, in the present circumstance, the procurement procedures are undertaken before signing the related Bank loan.

The rights and obligations of the Borrower and the providers of goods and works for the project are governed by the bidding documents, and by the contracts signed by the Borrower with the providers of goods and works.

In the case of the Lugovaya – Kyrgyz border section, however, the Kazakh Railways could implement the project using internal funds and without asking for any loan. Anyway the Consultant strongly recommend the adoption of international standards documents.

In fact, for major contracts involving the procurement of advanced technological equipment it is common practice to develop the procurement procedures through an International Competitive Bidding (ICB).

The objective of ICB is to provide all eligible prospective bidders with timely and adequate notification of a Borrower's requirements and an equal opportunity to bid for the required goods and works.

The bidding documents shall clearly state the type of contract to be entered into and contain the proposed contract provisions appropriate therefor. The most common types of contracts provide for payments on the basis of unit prices or a lump sum.

For the Lugovaya – Kyrgyz border (Kazakhstan): Lot 4.1 Civil Works and Permanent Way, the ADB Standard Tender Documents (STD) for Design-Build and Turn Key Contract with Single Stage bidding procedure have been taken as reference.

There are no universally-accepted definitions of the terms "design-build" and "turnkey", except that both involve the Contractor's total liability for design. For the Employer, such single-point responsibility may be advantageous, but the benefits maybe offset by having less control over the design process and more difficulty in imposing varied requirements.

Under the usual arrangements for a design-build contract, the Contractor is responsible for the design and provision, in accordance with the Employer's requirements, of works which may include any combination of engineering (including civil, mechanical, electrical, etc) and building works; and interim payments are made as construction proceeds.

The Conditions are also intended for use on turnkey contracts, under which the Employer's requirements usually include provision of a fully equipped facility, ready for operation (at the turn of the "key"). Turnkey contracts typically include design, construction, fixtures, fittings and equipment, the scope of which would be defined."

Turnkey contracts involve the contractor's single responsibility for design, manufacture, delivery, installation, testing, commissioning, training, etc.

In the Single Stage bidding procedure the bidders submit one envelope containing the price proposal and the technical proposal. The envelope is opened in public and the total amount of each bid and any alternative bid and other relevant details are read out and recorded. The bid is evaluated and the award of contract is made to the lowest evaluated substantially responsive bidder. The Single Stage bidding procedure is normally utilized for contracts where the plant to be designed and build is very well defined or where the civil works content is very high such as for roads, pipelines and power transmission line projects where there is not likely to be problems in the evaluation of alternative proposals for machinery or equipment.

In accordance with ADB established procedures, prequalification of bidders is required for civil works, turnkey contracts and contracts for the fabrication of expensive and technically complex items to ensure that only experienced and financially capable firms will submit bids.

ADB's Standard Procurement Documents (SPD) for the Prequalification of bidders are based on Master Procurement Documents prepared jointly by multilateral development banks and other public international financing institutions.

Therefore a combination of:

- ADB's SPD for Prequalification, and
- ADB's SBD for Design-Build and Turn Key Contracts with Single Stage procedure

has been adopted for the procurement of the telecommunications system of the Beyneu – Uzbek Border section.

The main data provided by the Consultant are on the results of the Detailed Design, and are namely:

- For the SPD for Prequalification:
 - Short description of the project
 - Major contract components
 - Estimated quantities of major components
 - Contract implementation period
- For the SBD for Design-Build and Turn Key Contracts with Single Stage procedure:
 - Employer's Requirements. Care must be taken when drafting the Employer's Requirements to ensure that the requirements are not restrictive. In the specification of standards of goods, materials and workmanship recognized international standards should be used as much as possible. Where other particular standards are specified, whether national standards of the Borrower's country or other standards, it should be state that goods, materials and workmanship meeting other authoritative standards and which promise to ensure equal or higher quality than the standards specified, will also be acceptable. Where a brand name of a product is specified it should always be qualified with the terms or equivalent. In addition to stating the requirements of the completed Works clearly the Employer Requirements Section should also include matters related to the execution of the Works to enable the bidders to gauge the extent of responsibility and to price the bid accordingly.

7. Conclusions

Following the positive results of the Feasibility Study, the Consultant has prepared the detailed design necessary for the development of the related tender documents

The comparison of the magnitude of the investment with the financial performance of the Kazakh Railways brings to the conclusion that such investment is affordable and that no specific financing mechanism has to be studied.

Anyway the Consultant strongly recommends the adoption of international standards documents to assure an International Competitive Bidding (ICB).

Consequently tenders documents should be used for launching a tender for Design-Build and Turn Key Contract related to the renewing of the permanent way of the Lugovaya – Kyrgyz Border railway section and some minor civil works.

The works include:

- civil works concerning earthworks and drainages;
- permanent way replacing works (for line and main line in stations, there including replacement of 1 turnout);
- rail welding and mechanical tension regulation;
- re-aligning, re-levelling and ballasting;
- civil works concerning re-pavement of some level crossings (L.C.).

Tender documents here attached have been prepared using international standards (ADB Guidelines) and can be straight used by the Kazakh Railways for launching the related tender.



Published July 2005

This publication has been produced with the assistance of the European Union.
The contents of this publication is the sole responsibility of Italferr S.p.A.
and can in no way be taken to reflect the views of the European Union.