

The European Union's Tacis TRACECA programme
for Armenia, Azerbaijan, Bulgaria, Georgia, Kazakhstan, Kyrgyzstan, Moldova, Romania, Tajikistan, Turkey,
Turkmenistan, Ukraine, Uzbekistan

Review of Railways Rehabilitation in Central Asia

for Kazakhstan, Kyrgyzstan, Tajikistan and Uzbekistan

Module B – Detailed Design and Tender

**Documents of the rehabilitation measures for the
Balykchi – Bishkek - Kazakh Border railway
section (Kyrgyzstan)**

October 2005



This project is funded by
the European Union



A project implemented by
Italferr S.p.A.



Review of Railway Rehabilitation in Central Asia
EUROPAID/116151/C/SV/MULTI

Tashkent, 31 July 2005
Reference № DPC.GC.CA 218/05

To the kind attention of:

Mr. Vadim TURDZELADZE
IGC TRACECA Permanent Secretariat
8/2 Aliyarbekov Str., AZ 1005
Baku, Azerbaijani Republic

Subject: Review of Railway Rehabilitation in Central Asia
(EUROPAID/116151/C/SV/MULTI)
Module B - Submission of Detailed Design and Tender Documents – Draft Report for
the *Balykchi – Bishkek – Kazakh Border (Kyrgyzstan) railway section*

Dear Mr. Turdzeladze,

Please, find here enclosed the following copy of Module B - Detailed Design and Tender Documents Draft Report for the Balykchi – Bishkek – Kazakh Border (Kyrgyzstan) railway section relating to the Project in subject:

- 1 bound copy in English
- 1 loose leaf copy in English
- 1 CD

In view of the large volume of materials to be translated, the Russian copy of the report will be followed at earliest possibility.

We cannot ensure that the comments received after 20th September can be included into the Final Report. Thus, we would be obliged if you can provide your comments at the soonest.

Respectfully,

Alessandro Veralli
(Project Director)

Report cover page

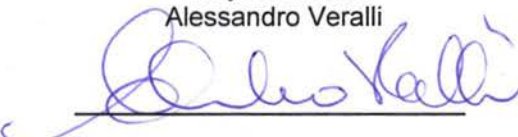
Project Title: Review of Railway Rehabilitation in Central Asia			
Project Number: 65290 – EuropeAid/116151/C/SV/Multi			
Countries: Kazakhstan, Kyrgyzstan, Tajikistan and Uzbekistan			
	Local operators		EC Consultant
Name:	Republican State Enterprise "KAZAKHSTAN TEMIR ZHOLY" Mr. Talaspekov K.S.	State Company "KYRGYZ TEMIR ZHOLU" Mr. Isaev K. Sh.	ITALFERR S.p.A. via Marsala, 53/67 – 00185 Rome – Italy Akhunbabaeva ul, 15 – 700047 Tashkent – Uzbekistan +39.06.49752721 +998.71.1321237 +39.06.49752209 +998.71.1321286 E-mail: a.veralli@italferr.it
Address:	98, Pobeda av., 473000, Astana, Kazakhstan	83, L. Tolstoy str., 720009, Bishkek, Kyrgyz Republic	
Tel:	(3172)935002	(998312) 657068	
Fax:	(3172) 935836	(996312) 651441	
Name:	Tajik Railways Mr. Khukumov A.	State Joint Stock Railway Company "UZBEKISTON TEMIR YULLARI" Mr. Ramatov A. J.	
Address:	35, Nazarshoev str., 734012 Dushanbe, Tajikistan	7, T. Shevchenko str., 700060 Tashkent, Uzbekistan	
Tel:	(992372) 216059	(99871) 1388414	
Fax:	(992372) 218334	(99871) 1320552	
Contact Person:	Project Director Alessandro Veralli		
Signature:			

Date of report: 31 October 2005

Authors of report: Project Team

EC M & E team	_____	_____	_____
	[name]	[signature]	[date]
NCU Kyrgyzstan	_____	_____	_____
	[name]	[signature]	[date]
TACIS Bureau	_____	_____	_____
[task manager]	[name]	[signature]	[date]

ABBREVIATIONS

ABLS	Automatic Block Line System
ADB	Asian Development Bank
ALC	Automatic Level Crossing
BC	Border crossing
CAR	Central Asian Republic
COTIF	Convention concerning the International Transport of Goods by Rail
CIS	Commonwealth of Independent States
CTC	Central Traffic Control
CWR	Continuous Welded Rail
EAEC	Euro Asian Economic Community
EBRD	European Bank for Reconstruction and Development
EC	European Commission
ECE	UN Economic Commission for Europe
ECO	Economic Cooperation Organisation
ECMT	European Council of Ministers of Transport
EDD	Unified Transit Tariff
EIRR	Economic Internal Rate of Return
ERII	Electric Relay Interlocking Installation
EU	European Union
FSU	Former Soviet Union
GDP	Gross Domestic Product
IGC	Intergovernmental Commission TRACECA
IMF	International Monetary Fund
IRU	International Road Transport Union
IsDB	Islamic Development Bank
JBIC	Japanese Bank for International Cooperation
KAZ	Kazakhstan
KGZ	Kyrgyz Republic
KTZ	Kazakhstan Temir Zholy (Kazakhstan national railways)
MLA	Multilateral Agreement on International Transport for Development of TRACECA
KZT	Kazakhstan Tenge
LC	Level Crossing
MKDII	Mechanic Key dependent Interlocking Installation
MOTC	Ministry of Transport and Communications
MTT	International Railway Tariff
OECD	Organisation of Economic Co-operation and Development
OSJD	Organisation for the Cooperation in Railways (based in Varshaw)
PRC	People's Republic of China
PW	Permanent Way (rails, sleepers, fastenings, ballast)
SIS	Static Interlocking System
SMGS	Agreement on International Railway Freight Transport
SPECA	Special Programme for the Economies in Central Asia
TA	Technical Assistance
TACIS	Technical Assistance for the Commonwealth of Independent States
TAJ	Tajikistan
TAR	Trans-Asian Railway
TEU	Twenty Foot Equivalent Unit
TIR	Transport International Routier
TOR	Terms of Reference
TRACECA	Transport Corridor Europe Caucasus Asia

UIC	Union International des Chemins of Fer (based in Paris)
UN	United Nations
UNDP	United Nations Development Programme
UNESCAP	United Nations Economic and Social Commission for Asia and the Pacific
USAID	United States Agency for International Development
USD	United States Dollar
UTY	Uzbek Temir Yullari (Uzbekistan national railways)
UZB	Uzbekistan
WTO	World Trade Organisation

TABLE OF CONTENTS

Executive summary	i
0. Project synopsis	1
1. Introduction	4
2. Description of the present situation	7
2.1 Permanent Way and earthworks	7
2.2 Stations	32
2.3 Level Crossings	33
2.4 Geology of the line	34
2.5 Structures and Drainages	35
2.6 Avalanche shed	39
2.7 Ballast quarry	41
3. Description of the designed improvements	44
3.1 Methodology for the line construction (Permanent Way)	47
3.1.1 Methodology 1	47
3.1.2 Methodology 2	50
3.2 Methodology for rail welding	54
3.2.1 Thermic welding	55
3.2.2 Electric Flash-butt Welding	57
3.2.3 Formation of Continuous Welded Rails (CWR)	58
3.3 Methodology for beam substitution and rehabilitation of bridges	59
3.4 Construction of a new avalanche shed	64
4. Purchase of machines (Lot 3.1)	65
4.1 Description and bill of quantity	65
4.2 Costs estimates	65
5. Purchase of permanent way materials (Lot 3.2)	66
5.1 Description and bill of quantity	66
5.2 Costs estimates	67
6. Purchase of a sleeper factory (Lot 3.3)	68
6.1 Description	68
6.2 Cost estimate	68
7. Detailed Design of Civil works (Lot 3.4)	69

7.1	Description and bill of quantities.....	69
7.2	Costs estimates.....	70
7.2.1	Unit costs.....	70
7.2.2	Cost calculation flow.....	71
8.	Implementation schedule.....	74
9.	Tender Documents.....	77
9.1	Introduction.....	77
9.2	The adopted philosophy for procurement.....	77
10.	Conclusions.....	81

Appendix 1 – Tolerance for rail welding

ANNEXES

- Annex A:** Lot 3.1 – Purchase of machines
- Annex B:** Lot 3.2 – Purchase of permanent way materials
- Annex C:** Lot 3.3 – Purchase of a sleeper factory
- Annex D:** Lot 3.4 – Civil works

Executive summary

After the development of the Feasibility Study (March 2005), project activities aimed at producing tender documents suitable for international tender for rehabilitation measures for the Balykchi – Bishkek – Kazakh Border railway section. The present document is to report the conclusions of such activities of Detailed Design and Tender Documents.

Historically the section under study belongs to the line Lugovaya – Bishkek – Balykchi as it is shown in the following Figure.

Figure - The Lugovaya – Bishkek – Balykchi railway line



After the collapse of the former Soviet Union, the line has been split into two sections because of the introduction of the national border between Kyrgyzstan and Kazakhstan: the Lugovaya - border (61 km) and the border – Bishkek – Balykchi (261 km).

The administrative change could not modify so much the situation since the two sections are still working in conjunction. Furthermore services along the line are operated up to Lugovaya by the Kyrgyz Railways and so they will be up to 2007 at least. This is why the report is often making reference to the whole line.

Besides this fact, improvements along the section from Balykchi to the border should be certainly managed by the Kyrgyz Railway Administration while the section up to Lugovaya belongs to the Kazakh Railways but maintenance/services are operated by the Kyrgyz Railways. Consequently the issue of the competence has required to consider two different Feasibility Studies and two different Tender Documents for rehabilitation measures concerning sections of the same line.

The development of activities for the Detailed Design and Tender Documents preparation has started from the feasibility study delivered in March 2005.

In the following meetings with Kyrgyz Railways representative, the proposed solution ("Option 1" of the Feasibility Study) was discussed and some changes have been requested and introduced in the Detailed Design as for instance: the reduction of the length of the avalanche shed to be built, the purchase of a welding machine, the rehabilitation of 5 bridges, the rehabilitation of the quarry for the ballast located nearby the station of Djil Aryk.

The proposed option represents the low cost alternative, mainly consisting in provision of PW materials, machines and plants that would permit to face the most urgent necessities of the line, as well as in building the indispensable structures to guarantee the line protection from land-slides.

The option considers in particular the following rehabilitation works:

- a. Civil works concerning earthworks;
- b. Permanent way replacing works;
- c. Existing permanent way rail welding and tension regulation;
- d. Re-alignment, leveling and ballast cleaning on the existing sections;
- e. Civil works concerning structures (basically bridges and avalanche shed).

The adopted option by the Feasibility Study considers that all activities (but major civil works like for the bridges and for the avalanche shed) will be basically carried out by the Kyrgyz Railways personnel during a sort of extraordinary maintenance which will be possible after purchasing materials, machines and plants.

Therefore four Lots have been considered for international tendering:

- Lot 3.1 – Purchase of machines
- Lot 3.2 – Purchase of Permanent Way materials
- Lot 3.3 – Purchase of a sleeper factory
- Lot 3.4 – Civil works

Lot 3.4 also includes the rehabilitation of the ballast quarry near Djil Aryk in order to reach a proper level of efficiency and increase the production needed for the rehabilitation of the railway track.

Lots 3.1 and 3.2 regard the purchase of those materials and machines which are needed for the rehabilitation works carried out directly by the Kyrgyz Railways. Lot 3.3 is for purchase of a sleeper factory and Lot 3.4 regards civil works (bridges, avalanche shed and quarry rehabilitation) both will be performed by a Contractor under a Design-Build and Turnkey contract.

Costs for each Lot have been estimated to be:

- Lot 3.1 – 8.4 millions US\$
- Lot 3.2 – 10.8 millions US\$
- Lot 3.3 – 2.0 millions US\$
- Lot 3.4 – 7.9 millions US\$

International standard Tender Documents for each Lot have been prepared by the Consultant to assure International Competitive Bidding.

**Module B – Detailed Design and Tender Documents of the rehabilitation measures
for the Balykchi – Bishkek – Kazakh Border railway section (Kyrgyzstan)**

For Lot 3.1 and Lot 3.2, the ADB Standard Tender Documents (STD) for Procurement of Goods have been taken as reference while for Lot 3.3 and Lot 3.4, the ADB Standard Bidding Documents (SBD) for Design-Build and Turnkey have been adopted.

In the case of Procurement of Goods the following steps have been considered:

- A - prequalification of bidders, and
- B - tender for procurement of goods (single stage)

In the case of the Design-Build and Turnkey tender the following steps have been included:

- A - prequalification of bidders, and
- B - design-build and turnkey tender (single stage)

In all cases the tenders should be launched using international standards but the work performed, leaves open the possibility of adopting guidelines of procurement of other bodies. Thus the approach doesn't prevent the Beneficiary to implement the project using other guidelines (i.e. World Bank, EBRD, national, etc.) simply taking the core part of the tender document, namely the technical drawings and specifications, and embedding them into a different set of standards documents.

The Consultant has presented such documents in separate Annexes (Annex A, B, C and D) which can be straight used for the tender just including some basic additional information from the Beneficiary (i.e. employer's name and address, representative of the employer, deadline for presentation, etc).

It is worth mentioning that the subdivision of the rehabilitation works in four lots involving smaller amounts of money can favour the releasing of a loan or of a grant. The last is certainly desirable due to the importance of the Balykchi – Bishkek – Kazakh Border railway line for the whole country and taking into account Kyrgyz Railways financial performance.

0. Project synopsis

Project Title:	Review of Railway Rehabilitation in Central Asia
Project Number:	65290 – EuropeAid/116151/C/SV/Multi
Country:	Kazakhstan, Kyrgyz Republic, Tajikistan, Uzbekistan

Wider project objectives: The development of viable, secure, safe and competitive transport routes linking the countries of Central Asia with Europe and other neighbouring countries. Strengthened border management capacity facilitating economic development, the movement of people and goods and the prevention of organised crime.

The object of the project is to carry out:

Module A / Analysis of the relevant national railway transport plans and any regional railway transport planning provisions.

Module B / Preparation of Technical and Economic Justifications to support and to attract the investments for the rehabilitation of railway lines in the Kyrgyz Republic, Kazakhstan and Uzbekistan for the purpose of increasing transportation capacities of these areas. Preparation of Feasibility study of measures for the maintenance, rehabilitation and renewal of the freight wagon fleet of the Tajik Railways.

Specific project objectives:

The project will carry out:

Module A /

- Overview of relevant traffic flows and forecasts, with special attention on freight transport from Central Asia towards Europe especially through TRACECA corridor;
- Identification of weaknesses and bottlenecks;
- Investigation on the cross-border elements, including co-operation in exchange of data and in customs (also with Afghanistan);
- Evaluation of multi-modal dimensions and possibilities for inter-operability;
- Harmonisation of standards and of operating procedures, with particular attention to compatibility with EU standards, in particular with regard to safety and security standards for the transportation of dangerous goods and oil products.

Module B /

Technical and Economic Feasibility Studies for the rehabilitation and construction of new railways lines. Pursuant to the Technical and Economic Justification data there will be prepared the loan applications

to the lending banks for the allocation of investments to implement the projects.

Feasibility Study of measures for the maintenance, rehabilitation and renewal of the freight wagon fleet of the Tajik Railways.

Planned outputs:

Module A /

- Recommendations concerning multimodal transport
- Recommendations on harmonisation of standards and operating procedures and interoperability.
- Recommendations on improvements of border-crossing procedures.
- Traffic forecasts.
- Tentative prioritisation of recommended actions.

Module B /

- Technical and economic feasibility study of the railway line sections previously identified in Kazakhstan, Kyrgyzstan and Uzbekistan.
- Draft tender document for the same sections.
- Definition of a policy for the maintenance, rehabilitation and renewal of wagons in Tajikistan.
- Feasibility study and preparation of tender documents for rehabilitation and renewal of the existing workshops and maintenance plants in Tajikistan.

Project activities:

Module A /

- A.1 – Collection and review of transport and economic studies. Data collection
- A.2 – Overview of traffic flows
- A.3 – Identification and review of physical, geopolitical, social and environmental issues
- A.4 – Analysis of national railway transport plans and regional railway transport planning provisions.
- A.5 – Traffic forecasts – Identification of capacity bottlenecks
- A.6 – Investigation of border-crossing issues – Recommendations for improvement at borders
- A.7 – Review of multimodal transport – Identification of development bottlenecks – Recommendations for improved services
- A.8 – Harmonisation of standards and of operating procedures – Recommendations on standards adaptation and improved interoperability
- A.9 – Selection of railway section to be submitted to feasibility study under Module B
- A.10 – Discussion with the Project Partners representatives
- A.11 – Refining output of Module A

Module B /

Activities to be developed in Kazakhstan, Kyrgyzstan and Uzbekistan:

- B.1 - Traffic Analysis

- B.2 - Technical Feasibility
- B.3 - Environmental Impact
- B.4 - Economic Viability
- B.5 - Detailed Design
- B.6 - Rehabilitation/construction implementation schedule
- B.7 - Draft tender documents preparation

Activities to be carried out in Tajikistan:

B.8 - Feasibility Study of measures for maintenance, rehabilitation and renewal of the freight wagon fleet of the Tajik Railways

Project starting date: 1 March 2004

Project duration: 20 months

1. Introduction

The present document is to report the conclusions of the activities of Detailed Design and Tender Documents developed following the Feasibility Study of the rehabilitation measures for the Balykchi – Bishkek – Kazakh Border railway section in Kyrgyzstan delivered in March 2005.

Historically the section under study belongs to the line Lugovaya – Bishkek – Balykchi as it is shown in the following Fig. 1-1.

Fig 1-1 The Lugovaya – Bishkek – Balykchi railway line



After the collapse of the former Soviet Union, the line has been split into two sections because of the introduction of the national border between Kyrgyzstan and Kazakhstan: the Lugovaya - border (61 km) and the border – Bishkek – Balykchi (261 km).

The administrative change could not modify so much the situation since the two sections are still working in conjunction. Furthermore services along the line are operated up to Lugovaya by the Kyrgyz Railways and so they will be up to 2007 at least. This is why the report is often making reference to the whole line.

Besides this fact, improvements along the section from Balykchi to the border should be certainly managed by the Kyrgyz Railway Administration while the section up to Lugovaya belongs to the Kazakhstan Railways but maintenance/services are operated by the Kyrgyz Railways. Consequently the issue of the competence has required to consider two different Feasibility Studies and two different Tender Documents for rehabilitation measures concerning sections of the same line.

Since it is the only railway connection in the north of the country and the more important in the whole country, the line is of strategic importance for Kyrgyzstan and for its economy.

Additional to that, Kyrgyzstan has not a railway linking northern cities (i.e. Bishkek) with the southern ones (i.e. Osh, Jal Alabad) and actually transport demand uses either road or the railway Balykchi - Bishkek - Lugovaya and then up to the South crossing Kazakhstan, Uzbekistan and also Tajikistan.

Improvements are consequently required for the line not to act as a bottleneck for the economic activities, to give access to the international markets and to connect Bishkek with the regional market.

The development of activities for the Detailed Design and Tender Documents preparation has started from the feasibility study delivered in March 2005. After that date, meetings have been held with the highest representatives of the Kyrgyz railways to discuss details of the option proposed in the Feasibility Study ("Option 1").

Comments have been positive and Kyrgyz Railways representative showed interest in the proposed solution, which has to consider the severe financial constraints of the Kyrgyz railways. Some changes have been requested and introduced in the Detailed Design as for instance: the reduction of the length of the avalanche shed to be built, the purchase of a welding machine, the rehabilitation of 5 bridges, the rehabilitation of the quarry for the ballast located nearby the station of Djil Aryk.

The proposed option represents the low cost alternative, mainly consisting in provision of PW materials, machines and plants that would permit to face the most urgent necessities of the line (starting from the Kazakh border – Bishkek section), as well as in building the indispensable structures to guarantee the line protection from land-slides. It would allow the acceleration of the capital maintenance of the remaining network putting at disposal recovered rails and machines to implement works with Kyrgyz railways personnel.

The option considers the following rehabilitation works:

- a. Civil works concerning earthworks;
- b. Permanent way replacing works
- c. Existing permanent way rail welding and tension regulation;
- d. Re-alignment, leveling and ballast cleaning on the existing sections;
- e. Civil works concerning structures (basically bridges and avalanche shed);

The activities concerning civil works (bridges and avalanche shed) are to be developed by a Contractor on the basis of a design and build contract.

All other works will be performed directly by the Kyrgyz Railways using internal personnel following the purchase of materials, machines and plants.

Therefore four lots have been considered:

- Lot 3.1 – Purchase of machines
- Lot 3.2 – Purchase of Permanent Way materials
- Lot 3.3 – Purchase of a sleeper factory
- Lot 3.4 – Civil works.

Lot 3.4 also includes the rehabilitation of the ballast quarry near Djil Aryk in order to reach a proper level of efficiency and increase the ballast production needed for the rehabilitation of the railway track.

In all cases the tender should be an international tender, but for Lot 3.3 and Lot 3.4 a Design-build and Turnkey (Single Stage) tender has been adopted while for Lot 3.1 and Lot 3.2 a Procurement of Goods Tender should be adopted.

In both cases the Consultant has developed tender documents packages using international standards (ADB standards). In the case of the Design-build and Turnkey tender the following steps have been included:

- A - prequalification of bidders, and
- B - design-build and turnkey tender (single stage)

In the case of "procurement of goods" the following steps have been considered:

- A - prequalification of bidders, and
- B - tender for procurement of goods (single stage)

Such approach of using international standards, leaves open the possibility of adopting guidelines of procurement of bodies other than ADB. Thus the approach doesn't prevent the Beneficiary to implement the project using other guidelines (i.e. World Bank, EBRD, national, etc.) simply taking the core part of the tender document, namely the technical drawings and specifications, and embedding them into a different set of standards documents.

The Consultant has presented such documents in separate Annexes (Annex A, B, C and D) which can be straight used for the tender just including some basic additional information from the Beneficiary (i.e. employer's name and address, representative of the employer, deadline for presentation, etc).

Finally, despite the positive results, it has to be pointed out that the project has been largely affected by the national Kyrgyz law covering "classified information".

As already explained, this heritage of the former Soviet Union prevents the access to a large series of information to foreign people including those geographically referred such as detailed maps, locations of stations/bridges/structures and including train timetable, traffic details, etc.

It has to be noted that such constraints could have also counterproductive effects vis-à-vis design standards required by IFIs for releasing a loan. Thus other projects could be preferred just for being better presented: for instance such constraint didn't allow the Consultant to produce plans and profiles and has required a working methodology more numerical/analytical, so less intuitive.

Notwithstanding Kyrgyz Railways have always been observant of the rules, they have been also very constructive in supporting experts staff both in the site visits and in the technical discussion.

It is worth mentioning that the subdivision of the rehabilitation works in four lots involving smaller amounts of money can favour the releasing of a loan or of a grant. The last is certainly desirable due to the importance of the Balykchi – Bishkek – Kazakh Border railway line for the whole country and taking into account Kyrgyz Railways financial performance.

2. Description of the present situation

2.1 Permanent Way and earthworks

In the mid XIX when the only type of transport between Central Asia and Kazakh steppes were horses and camels, caravan and mail roads were in condition of full decline. This circumstances and as well as the issues of strengthening military-political and economic influence of Russia in Central Asia, the possibility of wide use of rich sources of raw materials and sales market in the South-East of Russian empire, striving for direct exit from these regions to Siberia, stimulated the emergence in 1878 of the project on connection of Central Asia and Syberia.

The Turksib (Turkestan – Siberia) railway line was at last implemented during 1913-1931, creating conditions for wider development of cotton-growing in Central Asia Republics and providing them with grain from Siberia.

Construction and development of railways in Kyrgyz Republic was implemented by stages. Lugovaya – Pisppek (Bishkek 1) was put into operation in 1924, according to the project of construction of Turksib line. Due to some unclear reasons, the project was then changed and the construction of railways was carried on according to the economic possibilities, necessities and needs: Pishpek – Frunze (Bishkek 2) in 1929, Frunze – Kant in 1932 to connect a sugar refinery, Kant – Tokmak in 1941, Tokmak – Bystrovka in 1942, Bystrovka – Ribachye (Balykchi) in 1950.

After the collapse of former Soviet Union (1991), the Lugovaya – Kazakh border section, in spite of being in Kazakh republic territory, continue up till now to be maintained and operated by Kyrgyz railways. Meetings were held recently between Kazakh and Kyrgyz governments to agree the passage of this section to the operation and maintenance of Kazakh railways.

As the Consultant collected information about a probable passage of this line to Kazakh railways within the 2007, Lugovaya – Kyrgyz border and Balykchi – Bishkek – Kazakh Border were considered separately.

The description of the existing Balykchi-Kazakh border line section can be done in the frame of the definitions established in line with the former Soviet railway rules (which for instance has been substantially absorbed by Uzbek Railways by the order 70”H” dated 09.11.95), concerning types and elements of permanent way, track works, maintenance and periodicity of their execution. In fact, even if the line under study for geographic and administrative reasons is located in Kyrgyzstan, it has been assumed by this Consultant that such rationale could be applied in terms of line classification and therefore of simulation of the future needs for line maintenance, according to the classification that will be recovered after the rehabilitation works.

From the following tables 2.1-1 and 2.1-2 the line classification in **categories**, by their technical characteristics, and in **groups**, by density of freight traffic, is possible.

Table 2.1-1 Track classification

Track group	Density of freight traffic, mln. tkm gross weight km/per year	Track category						Station, branch and other tracks	
		1	2	3	4	5	6		7
		Speed: passenger trains is numerator; freight trains is denominator, km/h							
		121-140	101-120	81-100	61-80	41-60	40 and less		
		> 80	> 70	> 60	> 50	> 40	main reception/departure tracks		
		Main tracks							
A	> 80	1	1	1	2	2	3	5 class	
B	50-80	1	1	2	2	3	3		
C	25-50	1	2	2	3	3	4		
D	10-25	1	2	3	3	4	4		
E	10 and less	2	2	3	3	4	4		

Considering that the section under study had in the last years a freight traffic of $1,0 \div 1,5 \cdot 10^6$ /year gross tons, and that, on almost all the section, the speed is for the time being 70-50 km/h and that old wooden sleepers and worn out P50 rails are installed on the major part of the section, it is possible to conclude that this line is currently classified as an E4 line.

This classification will be used in the next Chapters and paragraphs.

Table 2.1-2 Technical terms and conditions for track laying and maintenance according to its class

Track class				
1	2	3	4	5
1. Superstructure constructions				
Continuous welded rail (CWR) tracks on reinforced concrete sleepers or link track on timber sleepers				
2. Types and characteristics of superstructure				
<p>New temperature –resistant R65 rails, 1 group, 1 class; new fastenings; new sleepers (impregnated timber, 1 group). Sleepers profile: on direct lines and curves R>1200 m - 1840 pcs/km; on curves with R<1200 m and less - 2000 pcs/km. Ballast: gravel or asbestos with the layer depth of 35 cm under timber sleepers ; 40 cm – under reinforced concrete sleepers.</p>	<p>New R65 rails or used ones in accordance with the Table 2.3.</p> <p>New or repaired used fastenings and sleepers – in accordance with Technical Conditions for the usage of used superstructure materials. Profile and the group of rails are the same as on the 1st and 2nd class tracks.</p> <p>Gravel or asbestos ballast, with layer depth of 25 cm under timber rails and 30 cm under reinforced concrete sleepers.</p>	<p>Used R65 rails – in accordance with the Technical Conditions for the usage of used superstructure rails. Used fastenings and sleepers, as a rule repaired ones.</p> <p>Sleeper profile is the same as on the 1 - 3 class rails. The laying of new sleepers of 2nd group is allowed.</p> <p>Ballast: gravel, asbestos, gravel and sand with layer depth of 20 cm under timber sleepers and 25 cm under reinforced concrete ones.</p>	<p>Rails, fastenings and sleepers are all used ones of all types, including the ones unusable in track laying of the 3rd and 4th class but not lighter than R 43.</p> <p>Interlacing of used reinforced concrete sleepers with timber ones is allowed.</p> <p>Sleepers profile: 1440 pcs/km on direct lines; 1600 pcs/km on curves with R< 650 m.</p> <p>Ballast depth underneath the sleeper not less than 15 cm.</p>	

Alignment and gradients

The total length of Balykchi - Kazakh border section is 261,4 km.

The alignment is mostly on straight from Kazakh border up to Bishkek 1 (5,2 km of curves out of 90 km in length), from Bishkek 1 to Balykchi the number of curves greatly increases as well as the slopes especially in the last part of the section up to a total of 44,4 km out of 172 km in length. Every circular curve is provided with parabolic transition curves at the beginning and at the end.

**Module B – Detailed Design and Tender Documents of the rehabilitation measures
for the Balykchi – Bishkek – Kazakh Border railway section (Kyrgyzstan)**

- The minimum curve radius is 260 m.
- The maximum cantilever is 150 mm.
- The maximum gradient is 20 ‰, at chainage km 3892 between Djil Aryk and P 148.
- The maximum allowed load is 23 t/axle.

The Table 2.1-3, shown in the following pages, contains all the relevant data about the line:

- curves and their characteristics (length, deviation angle, radius, cant),
- level crossings location,
- stations with beginning, end and centre (building) chainage. The chainage is referred to the first and last turnouts blades.

**Module B – Detailed Design and Tender Documents of the rehabilitation measures
for the Balykchi – Bishkek – Kazakh Border railway section (Kyrgyzstan)**

Table 2.1 - 3

1/6

Element	Start (km)	End (km)	Station centre (km)	Cant (cm)	Deviation angle (degree)		Radius (m)	Curve length (m)	Transition length (m)
					-60				
Kazakh border	3685.746	3686.816	3686.324						
L.C.	3686.956								
Curve	3688.654	3689.036		7	20	8	800	381	100
Curve	3689.161	3689.522		6	18	42	800	361	100
L.C.	3690.142								
L.C.	3691.960								
Curve	3692.371	3692.712		5	11	44	1000	341	40
Curve	3693.075	3693.485		6	25	3	800	409	60
Curve	3693.799	3694.066		6	13	20	900	269	60
Curve	3697.569	3697.606		4	1	40	2000	146	20
	3697.606	3697.792		2	0	37	3600	96	20
L.C.	3698.967								
L.C.	3702.417								
Kaindi	3702.578	3703.838	3703.322						
Curve	3705.268	3705.467		11	8	51	900	159	40
L.C.	3705.425								
Curve	3705.803	3706.038		4	4	56	2500	236	20
L.C.	3712.066								
Curve	3715.164	3715.555		0	9	42	2200	391	20
L.C.	3715.900								
Curve	3716.133	3716.354		3	5	10	2000	220	40
L.C.	3717.088								
Curve	3717.420	3717.662		4	6	23	2000	242	20
Kara-Balta	3717.960	3719.116	3718.242						
L.C.	3720.169								
L.C.	3722.456								
L.C.	3724.100								
L.C.	3726.617								
R-141	3730.419	3731.506	3730.908						
Curve	3733.122	3733.401		5	12	24	1100	278	40
L.C.	3733.964								
L.C.	3737.029								
Curve	3738.638	3739.063		10	32	41	640	425	60
Belovodskaja	3739.682	3741.042	3740.092						
L.C.	3739.861								
L.C.	3741.943								
Curve	3742.393	3742.588		5	5	0	2000	194	20
Curve	3745.184	3745.463		5	13	55	900	278	60
L.C.	3747.418								
Curve	3753.382	3753.527		5	4	24	1500	145	30
Shopokovo	3754.716	3755.787	3755.435						
L.C.	3756.079								
L.C.	3761.310								
Soklugh	3764.750	3765.850	3765.212						
L.C.	3769.560								
L.C.	3771.950								
Bishkek - I	3773.267	3776.248	3775.591						

**Module B – Detailed Design and Tender Documents of the rehabilitation measures
for the Balykchi – Bishkek – Kazakh Border railway section (Kyrgyzstan)**

2/6

Element	Start (km)	End (km)	Station centre (km)	Cant (cm)	Deviation angle (degree)		Radius (m)	Curve length (m)	Transition length (m)
						-60			
Curve	3775.124	3775.183		0	1	35	500	66	40
Curve	3775.183	3775.341		2	4	28	1200	49	20
L.C.	3777.041								
Curve	3777.260	3777.490		0	16	4	600	228	60
L.C.	3778.094								
Curve	3779.022	3779.326		6	10	42	1200	303	80
L.C.	3779.461								
Bishkek - II	3779.558	3780.635	3780.062						
Curve	3780.784	3781.226		5	20	45	1000	442	20
Curve	3781.873	3782.184		5	10	3	1200	250	40
Curve	3783.057	3783.341		5	7	31	1100	244	100
Alamedin	3783.550	3784.654	3783.915						
Curve	3784.856	3785.032		3	3	43	1900	186	60
L.C.	3787.064								
Curve	3788.722	3788.938		3	5	36	1000	215	20
Curve	3790.738	3791.195		5	19	55	1200	458	40
L.C.	3791.261								
Curve	3792.716	3793.086		5	16	54	1000	370	40
Curve	3793.477	3793.693		5	11	9	800	236	60
Curve	3798.208	3798.809		3	15	29	2150	601	20
L.C.	3799.215								
Kant	3799.945	3801.114	3800.569						
L.C.	3801.224								
Curve	3803.003	3803.597		4	21	10	1500	594	40
L.C.	3804.717								
Curve	3804.720	3804.958		3	5	40	2000	238	40
Curve	3805.479	3805.872		7	32	15	600	393	60
Curve	3805.872	3806.260		9	24	4	600	372	120
Curve	3806.444	3806.602		2	3	43	1500	157	60
Curve	3806.623	3806.740		3	3	58	1400	117	20
Curve	3806.878	3806.986		1	3	38	1400	109	20
Curve	3807.022	3807.162		4	3	38	1900	140	20
L.C.	3807.295								
L.C.	3812.417								
Curve	3816.950	3817.221		4	7	10	2000	270	20
Ivanovka	3818.528	3819.435	3819.090						
L.C.	3819.522								
Curve	3819.512	3819.693		9	13	14	700	182	40
Curve	3819.693	3819.793		9	9	10	500	99	40
Curve	3819.819	3820.230		11	29	34	600	411	100
Curve	3820.426	3821.003		10	49	20	600	577	60
Curve	3821.118	3821.904		10	53	18	600	786	80
Curve	3821.924	3822.462		9	43	47	600	538	80
Curve	3823.115	3823.774		7	43	15	750	659	40
Curve	3823.788	3824.114		9	21	32	600	325	100
L.C.	3826.695								
Curve	3830.631	3831.298		3	18	17	2030	667	120

**Module B – Detailed Design and Tender Documents of the rehabilitation measures
 for the Balykchi – Bishkek – Kazakh Border railway section (Kyrgyzstan)**

3/6

Element	Start (km)	End (km)	Station centre (km)	Cant (cm)	Deviation angle (degree)		Radius (m)	Curve length (m)	Transition length (m)
					-60				
L.C.	3832.903								
Curve	3834.580	3834.963		6	8	60	1800	382	100
Curve	3835.838	3836.140		5	7	53	1900	301	40
L.C.	3836.792								
L.C.	3838.447								
Tokmak	3839.124	3840.326	3839.568						
Curve	3840.875	3841.731		4	21	40	2000	856	100
L.C.	3841.151								
L.C.	3844.947								
L.C.	3848.263								
L.C.	3852.476								
Curve	3856.257	3856.666		9	27	29	600	408	120
L.C.	3857.771								
Curve	3857.907	3858.279		8	24	15	600	372	120
L.C.	3864.543								
L.C.	3868.028								
Curve	3870.010	3870.685		9	58	37	600	674	60
Bystrovka	3870.789	3871.960	3871.521						
L.C.	3872.189								
Curve	3872.065	3873.272		8	103	48	600	1207	120
Curve	3873.307	3873.649		9	23	3	600	341	100
Curve	3876.122	3876.447		10	25	30	640	325	40
L.C.	3876.830								
Curve	3878.332	3878.510		3	4	58	1600	178	40
Curve	3880.460	3880.787		4	8	40	1900	327	40
Djil-Aryk	3883.592	3884.624	3884.336						
L.C.	3884.634								
Curve	3884.637	3884.934		10	48	55	300	296	40
Curve	3885.284	3885.573		6	26	14	500	288	60
Curve	3885.694	3885.870		8	22	21	400	166	40
Curve	3885.870	3886.004		8	5	27	1200	134	40
Curve	3887.913	3888.565		6	39	25	1000	652	80
L.C.	3888.891								
Curve	3890.620	3891.013		8	27	57	600	392	100
Curve	3891.152	3891.381		8	21	21	400	229	80
Curve	3891.432	3891.571		5	9	0	600	139	60
Curve	3891.657	3891.869		6	23	55	330	212	80
Curve	3891.872	3892.156		8	38	4	320	293	80
Curve	3892.203	3892.306		1	6	0	500	103	40
Curve	3892.441	3892.576		4	14	64	400	134	40
Curve	3892.576	3892.699		4	8	26	700	123	40
L.C.	3892.621								
Curve	3892.836	3893.219		8	33	48	800	383	100

**Module B – Detailed Design and Tender Documents of the rehabilitation measures
 for the Balykchi – Bishkek – Kazakh Border railway section (Kyrgyzstan)**

4/6

Element	Start (km)	End (km)	Station centre (km)	Cant (cm)	Deviation angle (degree)		Radius (m)	Curve length (m)	Transition length (m)
						-60			
Curve	3893.276	3893.507		9	26	51	300	270	90
Curve	3893.513	3893.716		6	13	2	500	204	90
Curve	3893.717	3893.916		8	24	58	320	199	60
Curve	3894.001	3894.224		9	26	20	900	223	90
Curve	3894.224	3894.695		9	80	22	300	471	50
Curve	3894.751	3895.065		9	37	35	309	314	120
Curve	3895.146	3895.734		6	90	27	500	588	60
Curve	3895.649	3895.829		9	20	59	300	180	70
Curve	3895.858	3896.047		5	10	26	600	189	80
Curve	3896.109	3896.344		8	34	10	300	235	80
Curve	3896.370	3896.776		10	56	8	300	406	50
Curve	3896.809	3897.138		10	45	44	300	329	90
Curve	3897.353	3897.447		1	1	56	2200	94	20
Curve	3897.638	3898.138		4	10	1	500	500	20
Curve	3897.776	3898.037		9	44	17	300	261	30
Curve	3898.046	3898.322		6	22	35	300	276	60
Curve	3898.274	3898.428		2	7	6	1000	154	30
Curve	3898.696	3898.851		1	13	22	450	155	60
L.C.	3898.928								
Curve	3899.031	3899.114		2	6	59	800	83	20
R-148	3899.160	3900.129	3899.660						
Curve	3899.582	3899.920		4	22	42	600	338	100
Curve	3900.150	3900.268		2	3	52	1600	118	20
Curve	3900.267	3900.339		1	2	44	1300	72	20
Curve	3900.339	3900.522		2	14	53	500	180	100
Curve	3900.522	3900.712		2	7	81	1400	190	20
Curve	3900.767	3900.882		2	12	12	400	115	30
Curve	3900.907	3901.191		10	40	56	300	284	70
Curve	3901.280	3901.613		2	22	8	500	333	140
Curve	3901.787	3901.957		6	15	50	400	170	50
Curve	3902.240	3902.555		5	22	4	610	315	80
Curve	3902.715	3902.945		8	22	52	400	230	70
Curve	3902.950	3903.178		10	32	45	400	228	70
Curve	3903.478	3903.692		4	15	21	500	214	80
Curve	3903.723	3903.933		6	14	58	500	210	80
Curve	3903.939	3904.166		8	24	0	400	227	60
Curve	3904.170	3904.391		5	20	10	400	221	80
Curve	3904.417	3904.546		6	9	82	500	129	50
Curve	3904.765	3905.009		8	33	13	300	244	70
Curve	3905.027	3905.255		8	32	5	300	228	60
Curve	3905.255	3905.434		7	19	32	350	179	50
Curve	3905.574	3905.662		2	4	1	1050	88	30
Curve	3905.683	3905.741		0	4	35	600	58	21

Module B – Detailed Design and Tender Documents of the rehabilitation measures for the Balykchi – Bishkek – Kazakh Border railway section (Kyrgyzstan)

5/6

Element	Start (km)	End (km)	Station centre (km)	Cant (cm)	Deviation angle (degree)		Radius (m)	Curve length (m)	Transition length (m)
						-60			
Curve	3905.741	3905.870		8	18	15	310	129	60
Curve	3905.891	3906.165		10	45	57	300	274	60
Curve	3906.224	3906.540		10	48	55	300	316	40
Curve	3906.600	3906.841		9	34	42	300	241	60
Curve	3906.867	3907.037		6	21	6	300	170	60
Curve	3907.067	3907.227		4	19	12	300	160	60
Curve	3907.351	3907.573		7	27	10	300	222	80
Curve	3907.606	3907.791		8	20	4	300	185	80
Curve	3907.798	3908.012		6	25	39	300	214	80
Curve	3908.148	3908.446		7	42	3	300	298	60
Curve	3908.806	3909.006		7	22	51	300	200	80
Curve	3909.030	3909.174		3	12	53	400	144	80
Curve	3909.288	3909.421		2	13	21	400	133	40
Curve	3909.425	3909.537		3	10	24	400	112	40
Curve	3909.662	3909.786		3	12	6	400	124	40
Curve	3910.125	3910.258		7	17	53	300	133	40
Curve	3910.259	3910.374		6	11	2	390	115	40
Curve	3910.400	3910.519		7	12	36	360	119	40
Curve	3910.926	3911.265		3	51	28	800	339	120
Curve	3912.200	3912.398		4	15	56	500	198	50
Curve	3912.402	3912.580		9	13	9	600	178	40
Curve	3912.628	3913.135		7	53	24	400	507	120
Curve	3913.365	3913.715		8	35	51	400	350	100
Curve	3913.737	3914.041		8	32	8	400	304	80
Curve	3915.453	3915.610		1	3	22	2000	157	40
Curve	3917.020	3917.412		7	23	49	530	392	130
Curve	3917.715	3918.265		9	11	28	450	550	80
Curve	3917.865	3917.999		10	17	42	300	134	80
Curve	3918.018	3918.219		7	20	57	330	201	80
Curve	3918.404	3918.605		7	11	10	830	201	40
Curve	3918.693	3919.021		9	45	28	360	328	80
Curve	3919.201	3919.363		8	17	33	300	162	70
Curve	3919.640	3920.025		6	25	24	600	385	120
Curve	3920.140	3920.520		10	57	29	290	380	90
Curve	3920.520	3920.821		10	43	6	320	301	60
Curve	3920.898	3921.066		6	15	27	400	168	60
Curve	3921.151	3921.350		11	23	9	370	199	100
Curve	3921.350	3921.552		9	16	56	480	202	100
Curve	3921.686	3922.043		7	24	26	650	357	80
Curve	3922.200	3922.371		1	40	19	2000	171	20
Curve	3922.497	3922.667		6	13	57	450	170	60
Curve	3922.734	3923.257		7	58	14	460	523	40
L.C.	3925.116								

6/6

Element	Start (km)	End (km)	Station centre (km)	Cant (cm)	Deviation angle (degree)		Radius (m)	Curve length (m)	Transition length (m)
					-60				
Curve	3926.302	3926.536		3	15	52	700	234	40
Curve	3926.678	3926.889		6	18	44	400	211	80
Curve	3926.916	3927.282		8	58	30	250	366	90
Curve	3927.484	3927.600		4	3	52	1300	116	30
Curve	3927.600	3927.738		6	8	59	500	138	60
Curve	3928.916	3929.305		6	28	35	620	389	80
Curve	3929.759	3930.351		7	58	40	500	592	60
Curve	3930.806	3931.089		17	34	58	300	283	100
Curve	3931.136	3931.337		3	9	14	1000	204	40
Curve	3931.464	3931.839		11	54	28	300	375	80
Curve	3932.243	3932.469		6	23	50	400	226	60
Curve	3932.716	3932.968		4	10	58	900	252	80
Curve	3933.902	3934.217		8	26	35	550	315	60
Curve	3934.583	3934.787		9	25	4	260	204	90
Curve	3934.789	3934.900		3	12	20	290	112	50
Curve	3934.900	3935.068		5	10	18	600	168	60
Curve	3935.331	3935.853		4	26	29	1000	522	60
Curve	3936.126	3936.411		5	19	35	600	285	80
Kojamat-Kurkol	3936.746	3937.509	3936.941						
L.C.	3938.255								
Curve	3938.272	3938.583		2	8	50	1500	311	80
Curve	3941.959	3942.399		3	12	2	2000	440	20
L.C.	3946.590								
Curve	3946.662	3947.137		5	36	48	600	475	90
Balykchi	3947.175	3948.683	3947.757						
End point	3954.300								

Line formation

The line formation from Kazakh border to Bishkek 1 and from Bishkek 1 up to the station of Djil Arik is constituted by embankments 1+3 m high. From Djil Arik, situated at 800 m above sea level, the line climbs tortuously with a formation mainly in cut or semi cut along the Boomy canyon up to Balykchi, the last station, situated on the shore of the Issyk Kul lake at 1600 m above sea level.

The standard cross section of the formation is reported on Figures 2.1 – 1, 2 and 3 in which a slope of about 6% towards both sides, starting from a central strip 2,3 m wide, can be observed.

The top surface of the embankment width varies from 6,0 m to 7,1 m.

Fig. 2.1 – 1 Standard embankment cross section

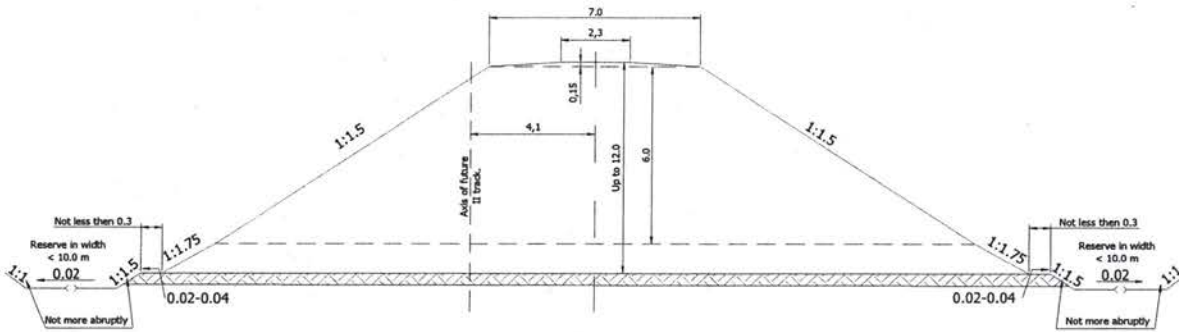

Typical cross structure of embankment in height up to 12 m from clay soils, fine and powdery sand and it is easy weathered rock.
The note: At erection of embankments from dry sand with a corner of a natural slope less than 340 their slopes are arranged more gentle slope.

Fig. 2.1 – 2 Standard cutting cross section

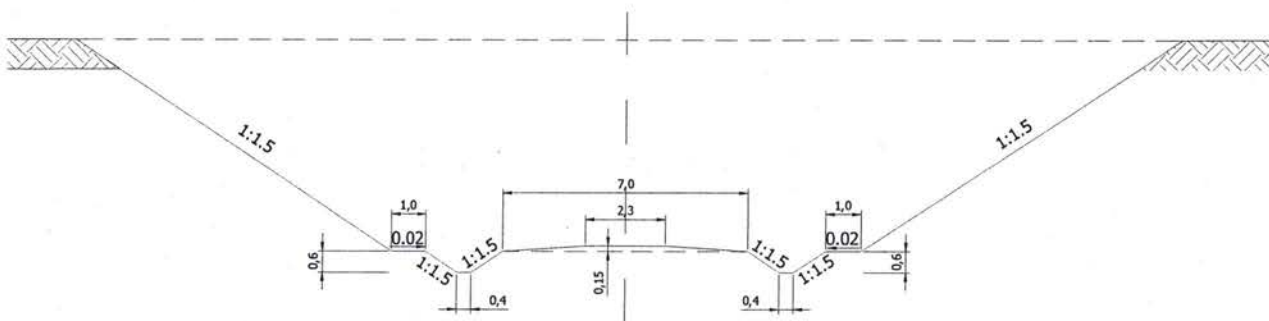

Typical cross a profile of a ditch depth up to 12 m in loess-like soils and a loess, silty loams, fine and powdery sands, semi-rocky breeds and loams.
The note: At height of a slope up to 2 m out of ditch's shelves are not arranged.

Fig. 2.1 – 3 Standard semi-cut cross section

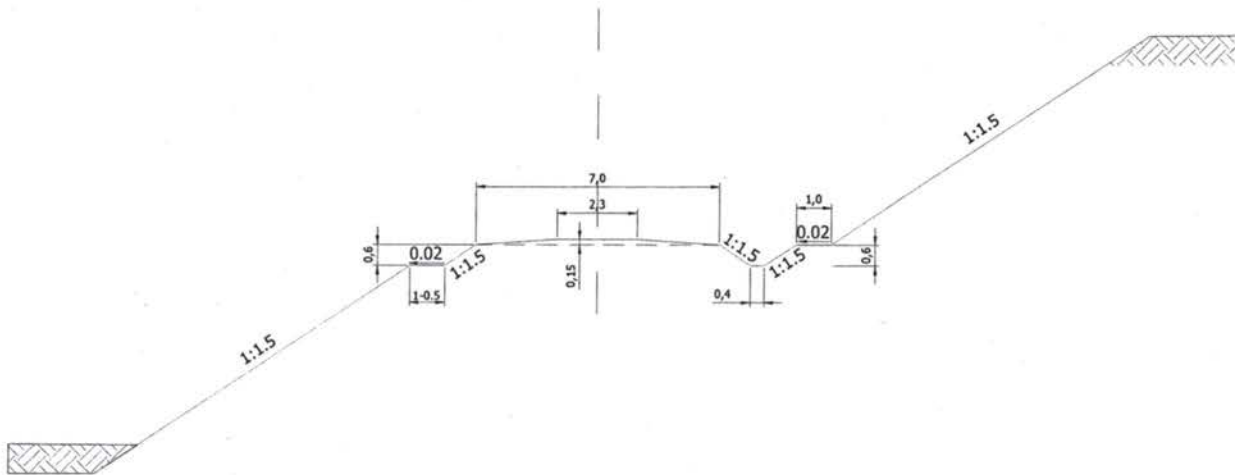

Typical cross section of a wide-cut formation

Superstructure

The typical superstructure cross-sections on straight track and on curve are shown in Fig. 2.1 – 4. On the top surface of the embankment is laid down a sandy gravel layer 0,2+0,3 m thick, and a ballast layer 0,20+0,35 m thick under sleepers.

Along the main line of the track section these are the technical characteristics:

- the sandy gravel layer and the ballast layer are, respectively, 0,2 and 0,3 m thick,
- both wooden and concrete sleepers are installed (see Fig. 2.1 – 5 and 2.1 – 6); they are laid down at a distance of 0,54 m / 0,50 m between their axels on straight / on curves of radius less than 1200 m (1840 / 2000 sleepers per km),
- P50 and P65 type of rails are laid down (see Fig. 2.1 – 7).
- fastenings rail-wooden sleepers and rail-reinforced concrete sleepers are shown in Fig. 2.1 – 8.

Fig. 2.1 – 4 Typical superstructure cross sections on straight track and on curve

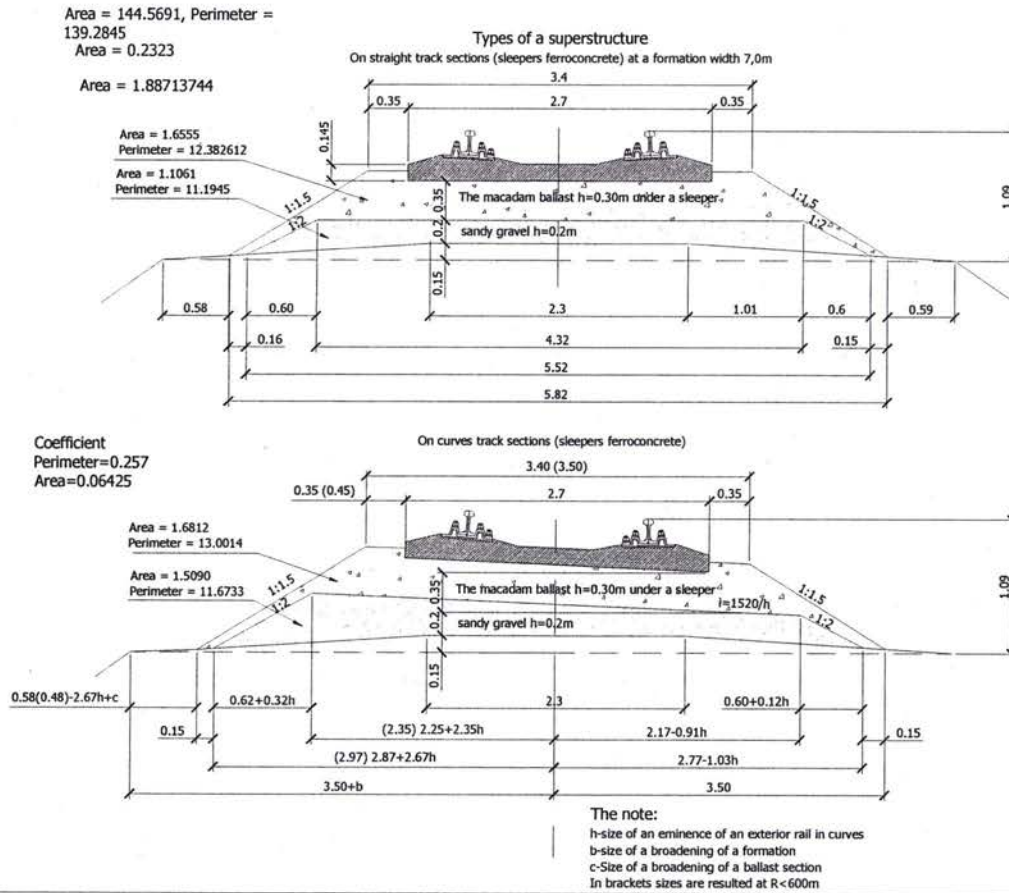
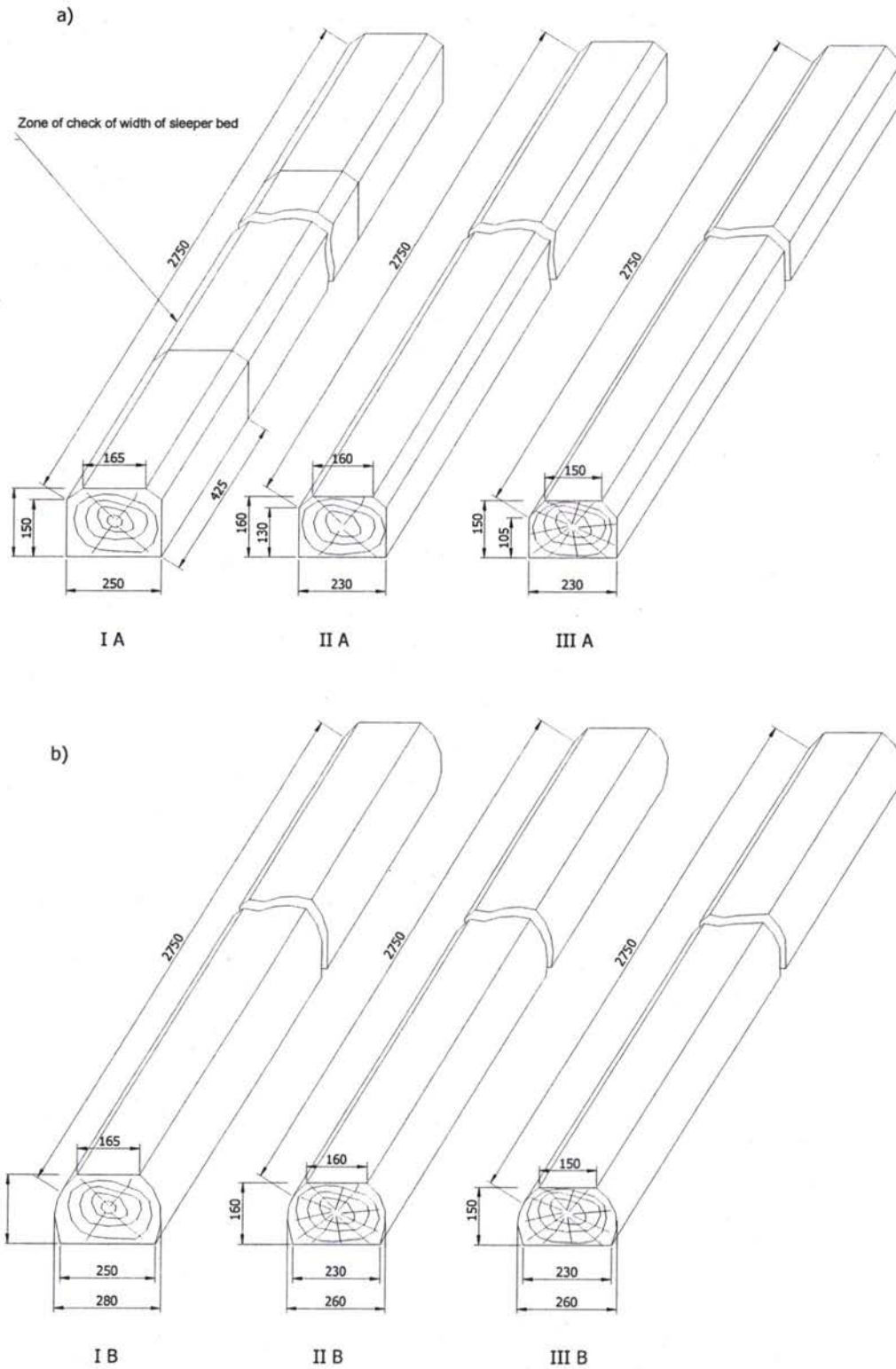
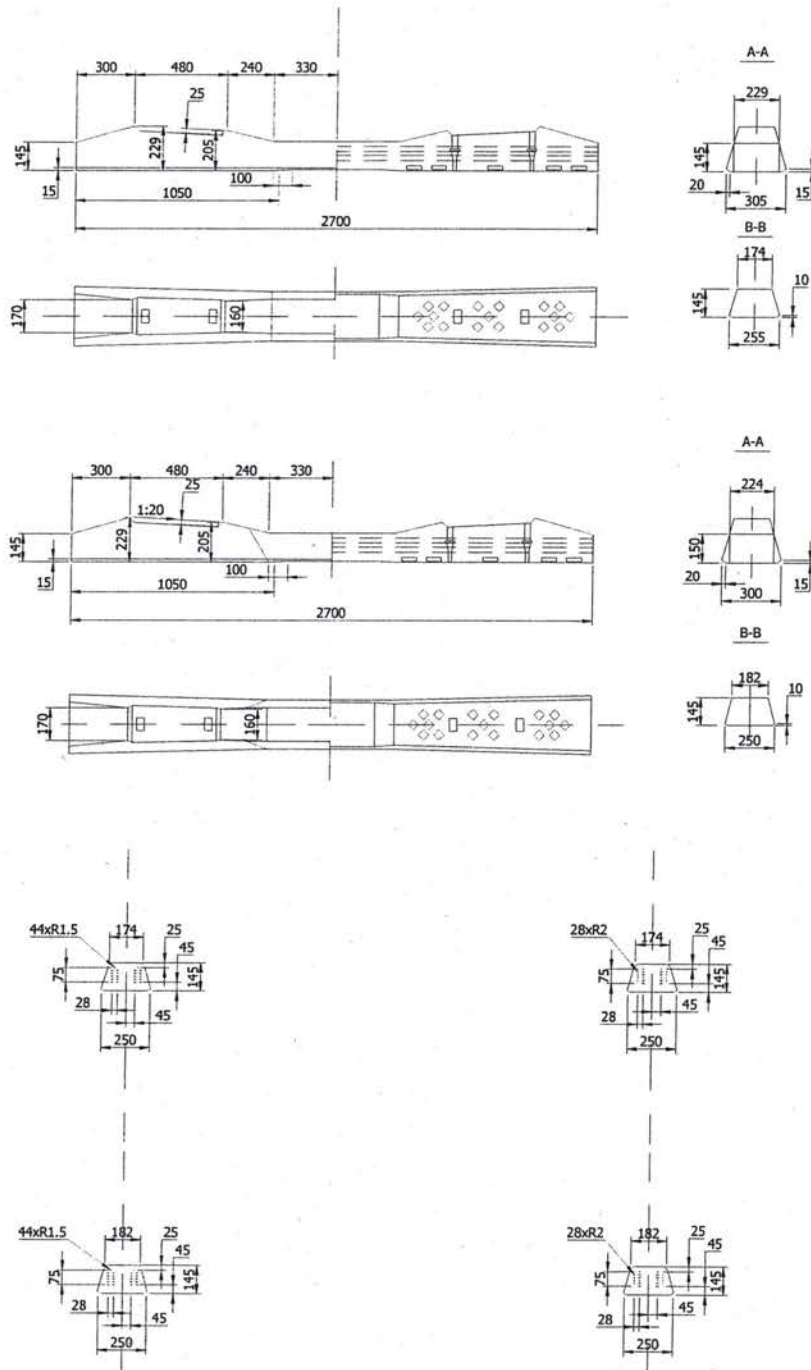

Fig. 2.1 –5 Wooden sleepers



Types of timber sleepers:
a) Edging; b) not edging.

Fig. 2.1 - 6 Ferroconcrete sleepers



Design of ferroconcrete sleepers
 a - such as C-73-1; b - such as C-73-2; c - cross sections and reinforcing of sleepers C-73-1; d - cross sections and reinforcing of sleepers such as C-73-2.

The appendix 8-4

Fig. 2.1 – 7 Cross profiles of standard rails

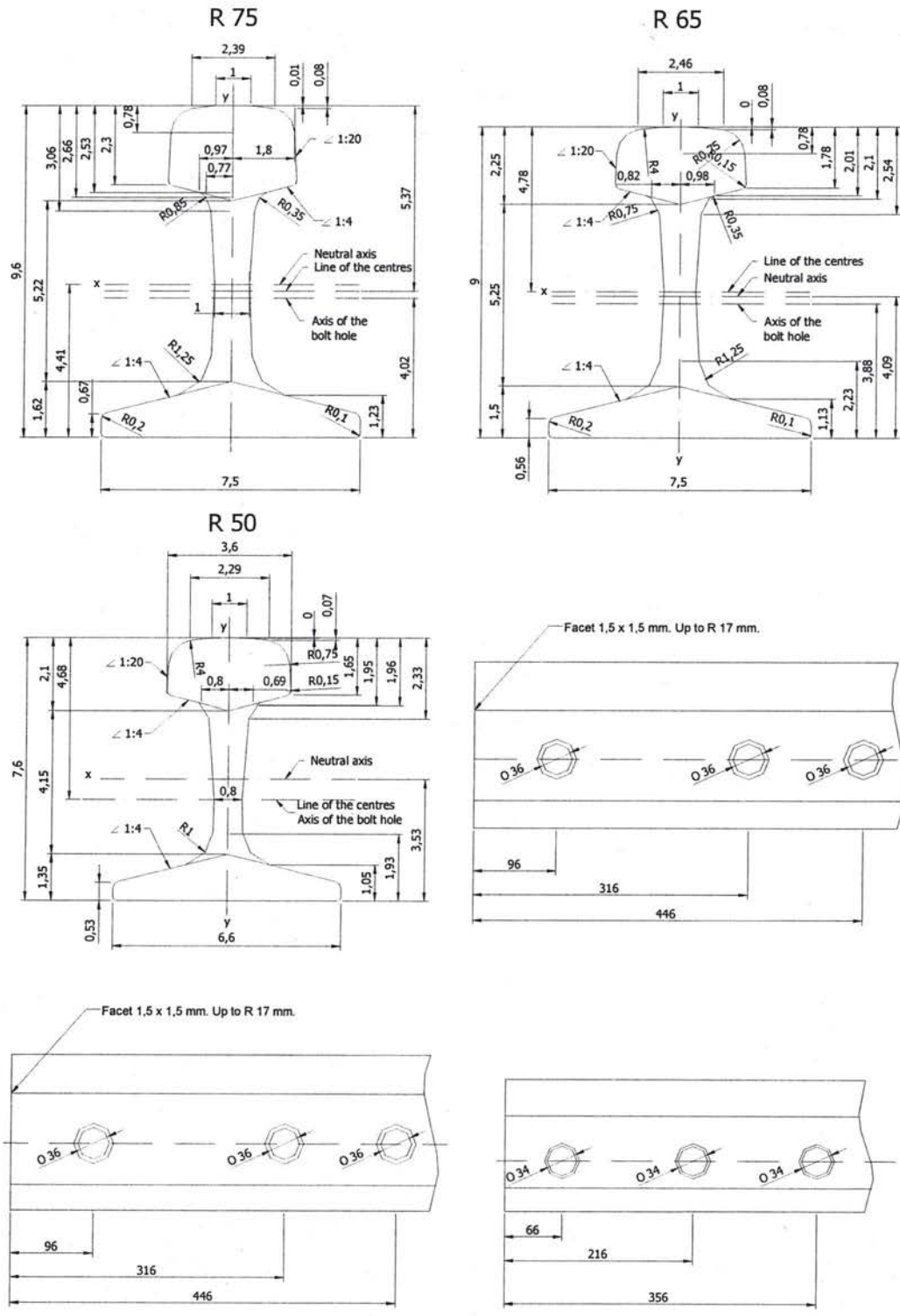

Cross profiles of standard rails (R75 R65 R50)

Fig. 2.1 – 8 Types of fastenings

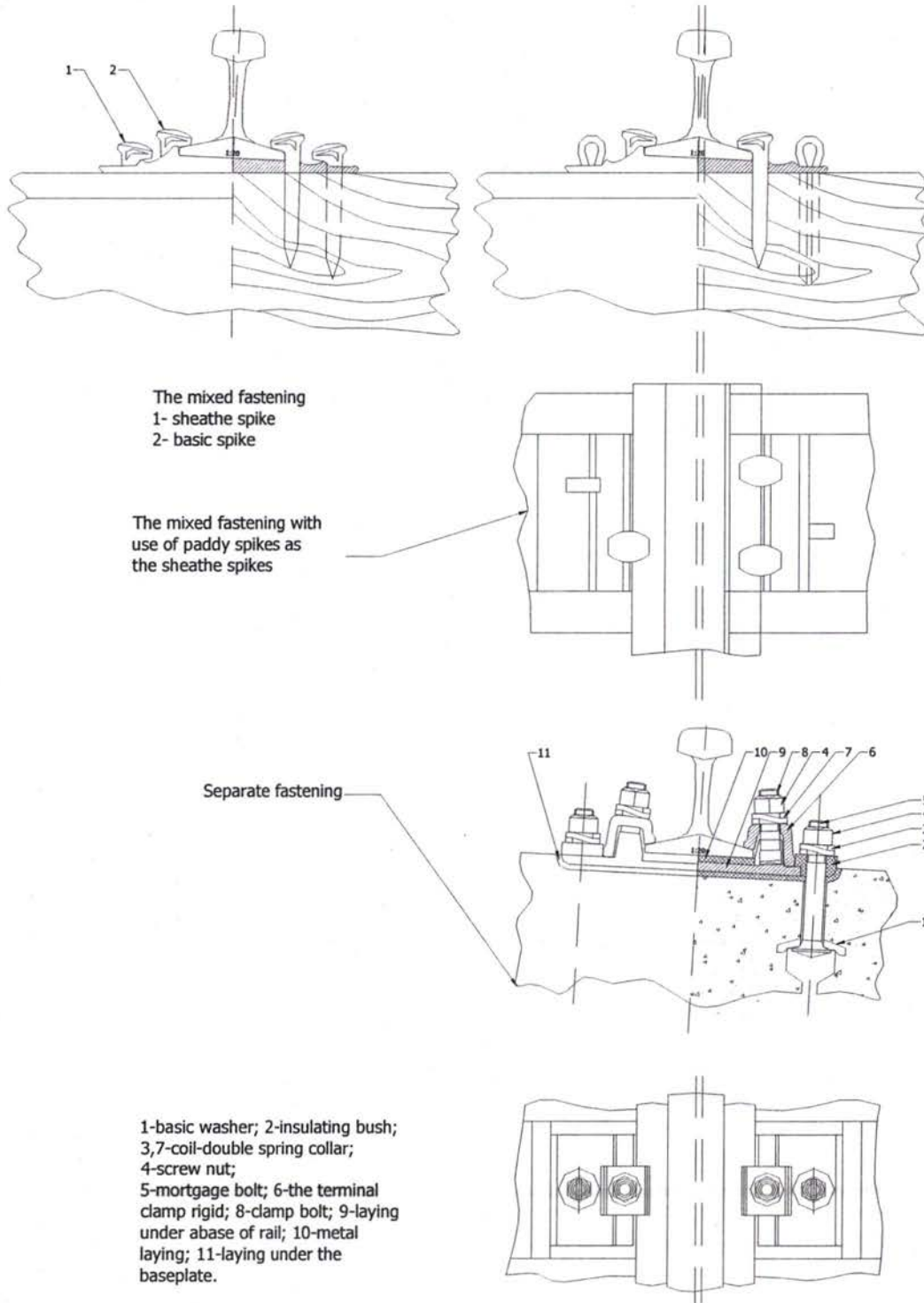

Normally rails are provided in 25 m bars; so, when they are laid down, a joint has to be done every 25 m. To reduce the hammering at the passage of trains, the joints on one rail are displaced 3 cm from the relevant ones on the other rail along the track

On lines equipped with concrete sleepers, a great reduction of hammering effect can be obtained by welding rails in long bars (continuous welded rails, cwr).

The great advantages of this technique, which will be described in the next paragraphs, are the increase in comfort for passengers and considerable reductions in noise, in wearing out of rails and rolling stocks, in costs of maintenance.

According to Russian standards the maximum length of welded rail bars in Central Asia countries is 900+1000 m. At the beginning and at the end of the long welded bars a sequence of joints and short bars 12,5 m long has to be laid down to allow a limited "expansion" of the long bar at the highest levels of temperature. The schemes to be implemented are reported on Fig. 2.1 – 9:

Fig. 2.1 - 9
(measures in m)

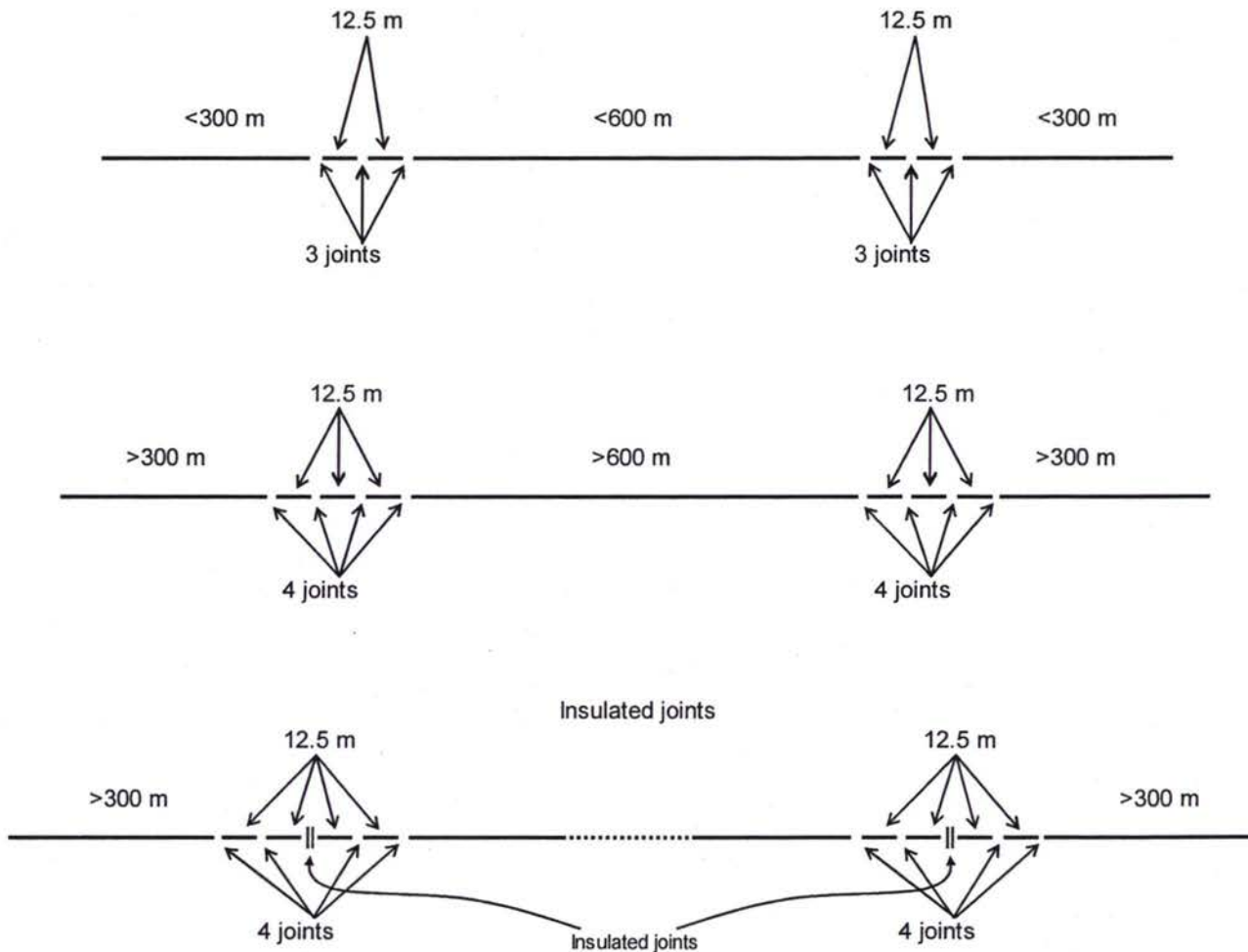

The situation of the existing rails, sleepers, implementation of cwr on the section under study can be summarized as it follows (see Table 2.1 – 4).

Table 2.1 - 4

Rehabilitation works for Lugovaya-Balykchi Line - Kazakh border-Balykchi section								
Permanent way and turnouts type								
Stations				PW type				
N.	Name	start km	end km	Line and station main lines			Stations turnouts on main track	
				Rail type	Sleepers	Length (m)	P65 1/11 (N.)	P50 1/11 (N.)
	<i>border</i>	0.000	3687.280					
		3687.280	3698.100	P65	W/C	10820		
		3698.100	3702.578	P65	C	4478		
1	<i>Kaindi</i>	3702.578	3703.838	P65	W/C	1093	5	
		3703.838	3717.960	P65	C	14122		
2	<i>Kara-Balta</i>	3717.960	3719.116	P65	W/C	989	5	
		3719.116	3729.28	P65	W/C	10164		
		3729.280	3730.419	P50	W/C	1139		
3	<i>R-141</i>	3730.419	3731.506	P50	W/C	954	4	
		3731.506	3739.682	P50	W/C	8176		
4	<i>Belovodskaja</i>	3739.682	3741.042	P65	W/C	1193	5	
		3741.042	3754.716	P50	W/C	13674		
5	<i>Shopokovo</i>	3754.716	3755.787	P65	W/C	904	5	
		3755.787	3764.750	P50	W/C	8963		
6	<i>Soklukh</i>	3764.750	3765.850	P50	W/C	967	4	
		3765.850	3773.267	P50	W/C	7417		
7	<i>Bishkek - I</i>	3773.267	3776.248	P50	W/C	2447	16	
		3776.248	3779.558	P50	W/C	3310		
8	<i>Bishkek - II</i>	3779.558	3780.635	P50	W/C	910	2	3
		3780.635	3783.550	P50	W/C	2915		
9	<i>Alamedin</i>	3783.550	3784.654	P50	W/C	904		6
		3784.654	3799.945	P50	W/C	15291		
10	<i>Kant</i>	3799.945	3801.114	P50	W/C	1002		5
		3801.114	3818.528	P50	W/C	17414		
11	<i>Ivanovka</i>	3818.528	3819.435	P50	W/C	774		4
		3819.435	3839.124	P50	W/C	19689		
12	<i>Tokmak</i>	3839.124	3840.326	P50	W/C	1035		5
		3840.326	3870.789	P50	W/C	30463		
13	<i>Bystrovka</i>	3870.789	3871.960	P50	W/C	1004		5
		3871.960	3883.592	P50	W/C	11632		
14	<i>Djil-Aryk</i>	3883.592	3884.624	P50	W/C	832		6
		3884.624	3899.160	P50	W/C	14536		
15	<i>R-148</i>	3899.160	3900.129	P50	W/C	869		3
		3900.129	3922.080	P50	W/C	21951		
		3922.080	3936.746	P43	W/C	14666		
16	<i>Kojamat-Kurkol</i>	3936.746	3937.509	P43	W/C	696		2
		3937.509	3947.175	P43	W/C	9666		
17	<i>Balykchi</i>	3947.175	3948.683	P43	W/C	1341		5
							46	44

The following table resumes the permanent way type in stations (main track) and line.

Table 2.1 - 5

<i>PW type Kazakh border-Balykchi section</i>		
	Line	Stations
		main track
W/C+P65	20,984	4,180
W+P43	24,332	2,037
W/C+P50	176,570	11,697
C+P65	18,600	

From the table could be observed that

- 43,764 km of track - between the border and few km after Kara-Balta station, and in Belovodskaja and Shopokovo stations - are equipped with P65 rails, out of them 18,6 km are on reinforced concrete sleepers and in continuous welded rails (cwr), the remaining part is formed by jointed 25 m bars on mixed wooden/concrete sleepers,
- 188,267 km are equipped with P50 rails on mixed wooden/concrete sleepers,
- 26,369 km are equipped with P43 rails on mixed wooden/concrete sleepers.

All these measures do not consider turnouts length.

Stations PW

The station main lines are generally provided with P50 rails, with the exception of:

- Kaindi,
- Kara – Balta,
- Belovodskaja,
- Shopokovo.

The existing turnouts are P65 tg 1/11 type on the station main lines from the Kazakh border up to Bishkek 2, with the exception of this last station in which two P65 tg 1/11 and three P50 tg1/11 type turnouts are installed. From Alamedin to Balykchi the station main lines are all equipped with P50tg1/11 turnouts.

In total, on station main track the following turnouts are currently installed:

- 44 P65 tangent 1:11,
- 46 P50 tangent 1:11.

Visit of the line

The line was visited by Consultant's experts in more than one occasion late in 2004 and in April/May 2005 from Kazakh border to Balykchi also by means of trolley put at their disposal.

In spite of the impossibility to obtain a number of "classified" documents, the railway officials were very collaborative and gave essential information that were needed for the present study.

PW defects of the line

During the site visit of the line the experts could check the present condition of the line and they could directly verify some information provided by the railway representatives. In detail, it has been noticed that:

- PW is old and worn out in many sections, rails type P50 and wooden sleepers are at their life limit, and their use leads to current heavy speed restrictions and to the sensitive risk of derailment for heavy trains (where the dynamic factor on the permanent way is higher);

- fastening devices, in particular those equipped on wooden sleepers, are old, and their fastening force is almost absent. Bolts and their parts are often worn out. Part of them is not properly working because of the conditions of the sleepers; old wooden sleepers are damaged and their retaining force on bolts and screw is low,
- rail junctions (every 25m for the sections not interested by the C.W.R.) are old and worn out, many bolts are missing for vibration and hammering,
- in correspondence with rail junction, hammering on the rails led to a rail consumption over the limits, in particular for those junction where the opening is larger than the maximum admitted,
- general conditions of the alignment geometry have been lost and their preservation is very difficult because of the deformation of the track panels and the bearing capacity of the formation level;
- in parts of the line the lateral paths of 0,59 cm on both sides of the top embankment surface disappeared for the action of raining waters and blowing wind; consequently quantities of ballast fell down and were wasted;
- in many cases the shoulders of ballast on the sides of sleepers, that in normal conditions are 0,35÷0,45 m wide, are non-existent;
- most of the ballast is extremely polluted with clayey soil and sand, particularly in stations;
- generally there are not drainage ditches.

Maximum speeds along the section

Conditions of permanent way elements can cause the necessity to reduce the maximum allowed speed on the lines. Generally this measure is taken when:

- the head of rails is worn out up to the admissible values,
- the ballast layer is highly polluted,
- the sleepers are no more in reliable condition for mechanical wear, decay and cracking,
- turnouts are obsolete and their elements worn out (in particular blades and crossings),
- existing cross section is greatly reduced by wind or rain water erosion,
- profile and alignment are far from the original designed ones,
- bridges and culverts needs interventions.

In the case of this section reductions of maximum speeds were imposed along all its length.

From the original 100 km/h speed for passenger trains and 90 km/h speed for freight trains, the maximum allowed speeds are, for the time being, the following:

Table 2.1 - 6

Rehabilitation works for Lugovaya-Balykchi Line - Kazakh border-Balykchi section		
"without project" speed		
Chainage	Section length	Speed
(km)	(km)	(km/h)
3626	61	70
3687	83	70
3770	178	50
3948		

For the original speed of the line, the Consultant has operated a detailed analysis based on the existing line geometrical value, aimed at calculating, per each curve and therefore per each section, the maximum admissible speed.

Module B – Detailed Design and Tender Documents of the rehabilitation measures for the Balykchi – Bishkek – Kazakh Border railway section (Kyrgyzstan)

The following table 2.1-7 shows the existing line geometrical maximum speeds, and the theoretical maximum speeds reached with the upgrading of some indicated curve cants (superelevation). Calculations have been carried out by taking into consideration the following values:

- maximum admissible value for “ a_{nc} ” (not compensated acceleration on curve)=0.55 m/sec²
- maximum admissible “ a_{nc} ” variation on the transition curves=0.20/0.15 m/sec³

These maximum speeds will be recovered with the rehabilitation works.

Table 2.1 – 7 Existing and future curves parameters. Future speeds.

Rehabilitation works for Lugovaya-Balykchi Line - Kazakh border-Balykchi section 1/4									
Existing and future line speed limits - curves modifications									
Existing situation					"with project" situation				
Curves			Existing cant	Existing R	Max alignment speed	Min length of transition curve	Theoretical Max speed	Cant to be increased	Future cant value
			(cm)	(m)	(km/h)	(m)	(km/h)		(cm)
Curve	3688.654	3689.036	7	800	100	98.62	100		
Curve	3689.161	3689.522	6	800	95	88.01	100	yes	7
Curve	3692.371	3692.712	5	1000	105	105.42	100		
Curve	3693.075	3693.485	6	800	95	88.01	100	yes	7
Curve	3693.799	3694.066	6	900	100	90.21	100		
Curve	3697.569	3697.606	4	2000	140	132.05	110		
Curve	3697.606	3697.792	2	3600	160	126.01	110		
Curve	3705.268	3705.467	11	900	115	96.92	110		
Curve	3705.803	3706.038	4	2500	150	124.34	110		
Curve	3715.164	3715.555	0	2200	125	126.86	110		
Curve	3716.133	3716.354	3	2000	135	129.50	110		
Curve	3717.420	3717.662	4	2000	140	132.05	110		
Curve	3733.122	3733.401	5	1100	110	110.05	110		
Curve	3738.638	3739.063	10	640	95	82.87	110	yes	14
Curve	3742.393	3742.588	5	2000	140	116.06	110		
Curve	3745.184	3745.463	5	900	100	101.63	110	yes	10
Curve	3753.382	3753.527	5	1500	125	114.64	110		
Curve	3775.124	3775.183	0	500	60	61.73	90	yes	12
Curve	3775.183	3775.341	2	1200	100	96.22	90		
Curve	3777.260	3777.490	0	600	65	65.40	90	yes	10
Curve	3779.022	3779.326	6	1200	115	102.25	90		
Bishkek - II	3779.558	3780.635					90		
Curve	3780.784	3781.226	5	1000	105	105.42	90		
Curve	3781.873	3782.184	5	1200	115	115.39	90		
Curve	3783.057	3783.341	5	1100	110	110.05	90		
Curve	3784.856	3785.032	3	1900	130	120.66	110		
Curve	3788.722	3788.938	3	1000	95	89.94	110	yes	7
Curve	3790.738	3791.195	5	1200	115	115.39	110		
Curve	3792.716	3793.086	5	1000	105	105.42	110	yes	7
Curve	3793.477	3793.693	5	800	90	78.79	110	yes	10
Curve	3798.208	3798.809	3	2150	135	117.24	110		
Curve	3803.003	3803.597	4	1500	120	109.76	90		
Curve	3804.720	3804.958	3	2000	135	129.50	90		
Curve	3805.479	3805.872	7	600	85	78.26	90	yes	10
Curve	3805.872	3806.260	9	600	90	81.05	90		
Curve	3806.444	3806.602	2	1500	110	101.65	90		

**Module B – Detailed Design and Tender Documents of the rehabilitation measures
for the Balykchi – Bishkek – Kazakh Border railway section (Kyrgyzstan)**

Rehabilitation works for Lugovaya-Balykchi Line - Kazakh border-Balykchi section 2/4									
Existing and future line speed limits - curves modifications									
Existing situation						"with project" situation			
Curves			Existing cant	Existing R	Max alignment speed	Min length of transition curve	Theoretical Max speed	Cant to be increased	Future cant value
			(cm)	(m)	(km/h)	(m)	(km/h)		(cm)
Curve	3806.623	3806.740	3	1400	115	115.80	110		
Curve	3806.878	3806.986	1	1400	105	106.15	110	yes	2
Curve	3807.022	3807.162	4	1900	135	123.33	110		
Curve	3816.950	3817.221	4	2000	140	132.05	110		
Curve	3819.512	3819.693	9	700	100	101.29	90		
Curve	3819.693	3819.793	9	500	90	64.05	90		
Curve	3819.819	3820.230	11	600	95	84.77	90		
Curve	3820.426	3821.003	10	600	95	95.63	90		
Curve	3821.118	3821.904	10	600	95	95.63	90		
Curve	3821.924	3822.462	9	600	90	81.05	90		
Curve	3823.115	3823.774	7	750	95	87.36	90		
Curve	3823.788	3824.114	9	600	90	81.05	90		
Curve	3830.631	3831.298	3	2030	135	126.91	110		
Curve	3834.580	3834.963	6	1800	140	121.84	110		
Curve	3835.838	3836.140	5	1900	140	126.38	110		
Curve	3840.875	3841.731	4	2000	140	132.05	110		
Curve	3856.257	3856.666	9	600	90	81.05	90		
Curve	3857.907	3858.279	8	600	90	91.34	90		
Curve	3870.010	3870.685	9	600	90	81.05	90		
Curve	3872.065	3873.272	8	600	90	91.34	90		
Curve	3873.307	3873.649	9	600	90	81.05	90		
Curve	3876.122	3876.447	10	640	95	82.87	90		
Curve	3878.332	3878.510	3	1600	120	113.18	90		
Curve	3880.460	3880.787	4	1900	135	123.33	90		
Curve	3884.637	3884.934	10	300	65	56.53	60		
Curve	3885.284	3885.573	6	500	75	69.14	60		
Curve	3885.694	3885.870	8	400	70	58.54	60		
Curve	3885.870	3886.004	8	1200	125	118.30	60		
Curve	3887.913	3888.565	6	1000	105	93.42	60		
Curve	3890.620	3891.013	8	600	90	91.34	60		
Curve	3891.152	3891.381	8	400	70	58.54	60		
Curve	3891.432	3891.571	5	600	80	76.23	60		
Curve	3891.657	3891.869	6	330	60	52.39	60		
Curve	3891.872	3892.156	8	320	70		60		
Curve	3892.203	3892.306	1	500	60	54.87	60		
Curve	3892.441	3892.576	4	400	60	49.74	60		
Curve	3892.576	3892.699	4	700	85	86.51	60		
Curve	3892.836	3893.219	8	800	100	87.20	60		
Curve	3893.276	3893.507	9	300	65	63.96	60		
Curve	3893.513	3893.716	6	500	75	69.14	60		
Curve	3893.717	3893.916	8	320	70		60		
Curve	3894.001	3894.224	9	900	110	98.19	60		
Curve	3894.224	3894.695	9	300	65	63.96	60		
Curve	3894.751	3895.065	9	309	65	60.15	60		
Curve	3895.146	3895.734	6	500	75	69.14	60		
Curve	3895.649	3895.829	9	300	65	63.96	60		
Curve	3895.858	3896.047	5	600	80	76.23	60		

**Module B – Detailed Design and Tender Documents of the rehabilitation measures
for the Balykchi – Bishkek – Kazakh Border railway section (Kyrgyzstan)**

Rehabilitation works for Lugovaya-Balykchi Line - Kazakh border-Balykchi section 3/4									
Existing and future line speed limits - curves modifications									
Existing situation						"with project" situation			
Curves			Existing cant	Existing R	Max alignment speed	Min length of transition curve	Theoretical Max speed	Cant to be increased	Future cant value
			(cm)	(m)	(km/h)	(m)	(km/h)		(cm)
Curve	3896.109	3896.344	8	300	60	48.03	60		
Curve	3896.370	3896.776	10	300	65	56.53	60		
Curve	3896.809	3897.138	10	300	65	56.53	60		
Curve	3897.353	3897.447	1	2200	130	127.84	60		
Curve	3897.638	3898.138	4	500	70	66.03	60		
Curve	3897.776	3898.037	9	300	65	63.96	60		
Curve	3898.046	3898.322	6	300	55	41.54	60	yes	7
Curve	3898.274	3898.428	2	1000	90	83.60	60		
Curve	3898.696	3898.851	1	450	55	46.54	60	yes	2
Curve	3899.031	3899.114	2	800	80	73.17	60		
Curve	3899.582	3899.920	4	600	75	66.19	60		
Curve	3900.150	3900.268	2	1600	115	109.54	60		
Curve	3900.267	3900.339	1	1300	100	98.49	60		
Curve	3900.339	3900.522	2	500	65	63.63	60		
Curve	3900.522	3900.712	2	1400	110	110.71	60		
Curve	3900.767	3900.882	2	400	55	46.86	60	yes	3
Curve	3900.907	3901.191	10	300	65	56.53	60		
Curve	3901.280	3901.613	2	500	65	63.63	60		
Curve	3901.787	3901.957	6	400	65	53.54	60		
Curve	3902.240	3902.555	5	610	80	74.23	60		
Curve	3902.715	3902.945	8	400	70	58.54	60		
Curve	3902.950	3903.178	10	400	75	65.00	60		
Curve	3903.478	3903.692	4	500	70	66.03	60		
Curve	3903.723	3903.933	6	500	75	69.14	60		
Curve	3903.939	3904.166	8	400	70	58.54	60		
Curve	3904.170	3904.391	5	400	65	60.97	60		
Curve	3904.417	3904.546	6	500	75	69.14	60		
Curve	3904.765	3905.009	8	300	60	48.03	60		
Curve	3905.027	3905.255	8	300	60	48.03	60		
Curve	3905.255	3905.434	7	350	65	60.13	60		
Curve	3905.574	3905.662	2	1050	95	94.97	60		
Curve	3905.683	3905.741	0	600	65	65.40	60		
Curve	3905.741	3905.870	8	310	60	44.71	60		
Curve	3905.891	3906.165	10	300	65	56.53	60		
Curve	3906.224	3906.540	10	300	65	56.53	60		
Curve	3906.600	3906.841	9	300	65	63.96	60		
Curve	3906.867	3907.037	6	300	55	41.54	60	yes	7
Curve	3907.067	3907.227	4	300	55	54.11	60	yes	7
Curve	3907.351	3907.573	7	300	60	54.89	60		
Curve	3907.606	3907.791	8	300	60	48.03	60		
Curve	3907.798	3908.012	6	300	55	41.54	60	yes	7
Curve	3908.148	3908.446	7	300	60	54.89	60		
Curve	3908.806	3909.006	7	300	60	54.89	60		
Curve	3909.030	3909.174	3	400	60	56.59	60		
Curve	3909.288	3909.421	2	400	55	46.86	60	yes	3
Curve	3909.425	3909.537	3	400	60	56.59	60		
Curve	3909.662	3909.786	3	400	60	56.59	60		

**Module B – Detailed Design and Tender Documents of the rehabilitation measures
for the Balykchi – Bishkek – Kazakh Border railway section (Kyrgyzstan)**

Rehabilitation works for Lugovaya-Balykchi Line - Kazakh border-Balykchi section 4/4									
Existing and future line speed limits - curves modifications									
Existing situation						"with project" situation			
Curves			Existing cant	Existing R	Max alignment speed	Min length of transition curve	Theoretical Max speed	Cant to be increased	Future cant value
			(cm)	(m)	(km/h)	(m)	(km/h)		(cm)
Curve	3910.125	3910.258	7	300	60	54.89	60		
Curve	3910.259	3910.374	6	390	65	56.05	60		
Curve	3910.400	3910.519	7	360	65	57.01	60		
Curve	3910.926	3911.265	3	800	85	80.55	70		
Curve	3912.200	3912.398	4	500	70	66.03	70		
Curve	3912.402	3912.580	9	600	90	81.05	70		
Curve	3912.628	3913.135	7	400	70	66.54	70		
Curve	3913.365	3913.715	8	400	70	58.54	70		
Curve	3913.737	3914.041	8	400	70	58.54	70		
Curve	3915.453	3915.610	1	2000	125	125.26	70		
Curve	3917.020	3917.412	7	530	80	74.05	70		
Curve	3917.715	3918.265	9	450	80	80.30	70		
Curve	3917.865	3917.999	10	300	65	56.53	60		
Curve	3918.018	3918.219	7	330	60	45.54	60		
Curve	3918.404	3918.605	7	830	100	92.17	60		
Curve	3918.693	3919.021	9	360	70	64.15	60		
Curve	3919.201	3919.363	8	300	60	48.03	60		
Curve	3919.640	3920.025	6	600	80	67.08	60		
Curve	3920.140	3920.520	10	290	65	61.04	60		
Curve	3920.520	3920.821	10	320			60	yes	
Curve	3920.898	3921.066	6	400	65	53.54	60		
Curve	3921.151	3921.350	11	370	75	68.65	60		
Curve	3921.350	3921.552	9	480	80	70.14	60		
Curve	3921.686	3922.043	7	650	90	88.27	60		
Curve	3922.200	3922.371	1	2000	125	125.26	60		
Curve	3922.497	3922.667	6	450	70	60.92	60		
Curve	3922.734	3923.257	7	460	75	71.06	60		
Curve	3926.302	3926.536	3	700	80	77.09	60		
Curve	3926.678	3926.889	6	400	65	53.54	60		
Curve	3926.916	3927.282	8	250	55	44.82	60	yes	9
Curve	3927.484	3927.600	4	1300	115	114.60	70		
Curve	3927.600	3927.738	6	500	75	69.14	70		
Curve	3928.916	3929.305	6	620	85	83.26	70		
Curve	3929.759	3930.351	7	500	75	60.57	70		
Curve	3930.806	3931.089	17	300	75	55.25	70		
Curve	3931.136	3931.337	3	1000	95	89.94	70		
Curve	3931.464	3931.839	11	300	65	49.10	70	yes	12
Curve	3932.243	3932.469	6	400	65	53.54	70	yes	7
Curve	3932.716	3932.968	4	900	95	92.70	60		
Curve	3933.902	3934.217	8	550	85	81.85	60		
Curve	3934.583	3934.787	9	260	60	57.00	60		
Curve	3934.789	3934.900	3	290	50	44.45	60	yes	5
Curve	3934.900	3935.068	5	600	80	76.23	60		
Curve	3935.331	3935.853	4	1000	100	97.18	60		
Curve	3936.126	3936.411	5	600	80	76.23	60		
Curve	3938.272	3938.583	2	1500	110	101.65	60		
Curve	3941.959	3942.399	3	2000	135	129.50	60		
Curve	3946.662	3947.137	5	600	80	76.23	60		
Balykchi	3947.175	3948.683							

2.2 Stations

General

The approved solution doesn't consider interventions within stations but those related to the track. Notwithstanding that a description is here below given.

The line Bishkek-Balykchi is provided with 17 stations with a distance between 37 (longest section) and 4 km. Their main functions are:

- operation (train crossings and overcoming);
- train parking;
- rolling stock (for service, for shunting or for maintenance) parking;
- passenger service;
- link for branches.

The following table 2.2-1 resumes the stations position and distances on the Balykchi – Bishkek - Kazakh border line.

Table 2.2 – 1 Stations on the Balykchi- Bishkek- Kazakh border line

Rehabilitation works for Lugovaya-Balykchi Line - Kazakh border-Balykchi section					
Stations					
	Station name	Dimension (number of tracks)	kind of station	centre building chainage	Distance (km)
	Kazakh border			3687.280	16.042
1	Kaindi	5	medium	3703.322	14.920
2	Kara-Balta	7	large plant	3718.242	12.666
3	R-141	4	small/petroleum	3730.908	9.184
4	Belovodskaja	6	large plant	3740.092	15.343
5	Shopokovo	5	medium	3755.435	9.777
6	Soklukh	3	small	3765.212	10.379
7	Bishkek - I		large plant	3775.591	4.471
8	Bishkek - II	5	medium	3780.062	3.853
9	Alamedin	7	large plant	3783.915	16.654
10	Kant	6	large plant	3800.569	18.521
11	Ivanovka	5	medium	3819.090	20.478
12	Tokmak	11	large plant	3839.568	31.953
13	Bystrovka	5	medium	3871.521	

Module B – Detailed Design and Tender Documents of the rehabilitation measures for the Balykchi – Bishkek – Kazakh Border railway section (Kyrgyzstan)

					12.815
14	Djil-Aryk	6	medium	3884.336	
					15.324
15	R-148	2	small	3899.660	
					37.281
16	Kojamat-Kurkol	3	small	3936.941	
					10.816
17	Balykchi	11	large plant	3947.757	
	end of station			3948.683	0.926

2.3 Level Crossings

Along the Balykchi-Bishkek-Kazakh border railway section a total of 52 level crossings is present.

The level crossing protection system is only assured by crossing warning signals (traffic lights and Saint Andrew crosses) without barriers.

The warning signalling system is automatic: track circuits detect trains and activate warning indications at level crossings.

Usually in correspondence of the level crossings there are unpaved tracks and not proper roads. The pavement of the level crossing area is typically made of concrete blocks or rarely of wooden beams.

From general experience, the level of safety afforded by these devices on their own is insufficient. In the specific case of the Balykchi-Bishkek-Kazakh border railway line this protection system could be justified by the low intensity of rail traffic and by the trifling volume of road traffic.

Hereafter the position of each level crossing is listed:

Table 2.3-1

Kazakh border-Balykchi line Level Crossings position		
1	L.C.	3690.142
2	L.C.	3691.960
3	L.C.	3698.967
4	L.C.	3702.417
5	L.C.	3705.425
6	L.C.	3712.066
7	L.C.	3715.900
8	L.C.	3717.088
9	L.C.	3720.169
10	L.C.	3722.456
11	L.C.	3724.100
12	L.C.	3726.617
13	L.C.	3733.964
14	L.C.	3737.029
15	L.C.	3739.861
16	L.C.	3741.943
17	L.C.	3747.418
18	L.C.	3756.079
19	L.C.	3761.310
20	L.C.	3769.560
21	L.C.	3771.950
22	L.C.	3777.041

23	L.C.	3778.094
24	L.C.	3779.461
25	L.C.	3787.064
26	L.C.	3791.261
27	L.C.	3799.215
28	L.C.	3801.224
29	L.C.	3804.717
30	L.C.	3807.295
31	L.C.	3812.417
32	L.C.	3819.522
33	L.C.	3826.695
34	L.C.	3832.903
35	L.C.	3836.792
36	L.C.	3838.447
37	L.C.	3841.151
38	L.C.	3844.947
39	L.C.	3848.263
40	L.C.	3852.476
41	L.C.	3857.771
42	L.C.	3864.543
43	L.C.	3868.028
44	L.C.	3872.189
45	L.C.	3876.830
46	L.C.	3884.634
47	L.C.	3888.891
48	L.C.	3892.621
49	L.C.	3898.928
50	L.C.	3925.116
51	L.C.	3938.255
52	L.C.	3946.590

2.4 Geology of the line

The main section of the railway line, from the Kazakh border to approximately Djil Arik, is basically situated on flat areas presenting, however, a general, regional inclination to the north, towards the Chu River.

These areas, extending between the Kyrgyz range, at South and the Chu River, at North, are part of the vast southern extension of the catchment area of this river, tributary of the large Issyk – Kul interior basin.

Geologically said areas are mainly composed of Neocene molasses and Quaternary alluvial fans and alluvial sediments deposited by the numerous mountains rivers discharging from the Kyrgyz range to the north, as tributaries of the Chu river.

The groundwater and aquifers of these Quaternary sediments are recharged both by atmospheric precipitation and by river water infiltration.

Past Djil Arik the railway enters into mountainous areas, following the Chu River valley up to reach Balikchy, at the western edge of the Issik Kul Lake.

No critical engineering geological conditions for the existing railway have been observed along the Kazakh border – Bishkek section, while a more deep analysis has been performed for the Bishkek-Balykchi section.

The general geological configuration of the Bishkek – Balykchi railway section is examined on the basis of the available geological map of the Kyrgyz Republic and of the observations carried out during the site visits.

The section may be analysed according to the following three separate portions:

1. Bishkek – Djil Ariyk portion
2. Djil Ariyk – Koiamat portion
3. Koiamat – Balykchi portion.

1. Bishkek – Djil Aryk

The railway line runs in W-E direction on the quaternary plains extending south of the Chu River. The plains are formed by the alluvial deposits and alluvial terraces both of the Chu River and of the numerous rivers discharging from the mountains range at South. These alluvial sediments are composed of alternations of sands, gravels and pebbles of different petrography nature, and include also silt and clays layers.

2. Djil Ariyk – Koiamat

Beyond Djil Aryk the line turns southwards following the bottom of the Chu river valley that crosses the mountains range from North to South.

West of the river the mountains range has a latitudinal direction, developing westwards into the Kirkyzskij range. East of the river the direction of the mountains range changes to SW-NE, developing into the Kungey Alatau range, at the North of Issyk Kul lake.

The valley sides are generally formed by steep slopes, where the observed bedrock includes the following geological formations:

- Tertiary sedimentary rocks (sandstones, conglomerates, carbonates, marls and clay stones);
- Pre-Mesozoic sedimentary and volcanic rocks (sandstones, conglomerates, carbonates, andesites, basalts, porphyries, tuffs)
- Pre-Mesozoic intrusive formations (mainly Permian granites formations)

The above formations are intensively folded and faulted and, particularly the most competent rocks are always densely jointed.

3. Kojamat/Kurkol – Balykchi

Before reaching Kojamat/Kurkol the Chu River turns to East and the valley widens considerably, joining the plain of Balykchi, while the river turns again to South.

This large, flat part of the Chu valley and the adjoining plain of Balykchi are formed by alluvial deposits including recent alluvial and quaternary terraces composed of alternating sands, gravels and pebbles that covers the bedrock.

2.5 Structures and Drainages

Along the entire Lugovaya-Balykchi line there are 3 steel bridges, the longest one between Djil Aryk station and R148 (see Table 2.5 – 1) and 132 concrete bridges (see Table 2.5 – 2).

Table 2.5 – 1 - Steel bridges

Steel bridges		
Span	Length	number
(n)	(m)	(n)
1	26	1
1	64	1
1	9,8	1

Table 2.5 – 2 - Concrete bridges

Concrete bridges		
Span	Length	number
(n)	(m)	(n)
1	2,13	28
2	2,13	1
1	4,27	20
2	4,27	13
1	6,40	8
2	6,40	8
3	4,22	3
3	6,40	1
2	8,53	3
4	4,27	1
3	2,53	1
1	8,53	2
4	2,60	1
1	0,50	2
3	8,53	1
5	6,40	2
1	15,80	1
3	7,90	1
2	9,90	2
1	10,00	1
1	11,00	2
3	15,30	1
2	12,50	1
3	10,00	1
2	10,00	1
2	14,00	1
1	3,00	2
2	5,00	1
1	1,00	4
3	7,30	1
1	2,00	6
1	4,00	6
1	6,00	1
1	7,90	2
1	5,00	1
2	7,90	1
Total		132

The number of pipe culverts, box culverts and arch culverts is indicated in Table 2.5 – 3.

Table 2.5 – 3 - Culverts

Pipe culverts	
Pipes	number
(n)	(n)
1	204
2	28
3	2
>3	2(*)

(*) 5 and 8 pipes

Box culverts	
Boxes	number
(n)	(n)
1	24
2	11

Arch culverts	
number	
(n)	
164	

Five concrete bridges need rehabilitation works.

After the station of Djil Aryk on the way to Balykchi a bridge, crossing a left tributary of Chu River, presents some particular problems occurred during the last flood (see Fig. 2.5 - 1).

Fig. 2.5 – 1 – Bridge after Djil Aryk



At the bridge location the river bed is composed of recent alluvial sediments, while the river banks, few meter high, are cut through quaternary alluvial/colluvial terraces composed of gravels, pebbles and rock debris of various nature in abundant sandy – silt reddish matrix.

Evidence of scouring activities are present both on the bed and on the banks of the water course. The last flood has damaged one of the bridge abutments when the water over-flew the concrete channel coming from an upstream earth-fill dam. The reservoir of this dam is however completely filled up with alluvial and colluvial materials sedimented into the basin; therefore the channel, probably designed as the dam spillway with the function of controlling the floods discharge from reservoir, appears to have concluded its life.

Fig. 2.5 – 2 - Old concrete channel along the river bed

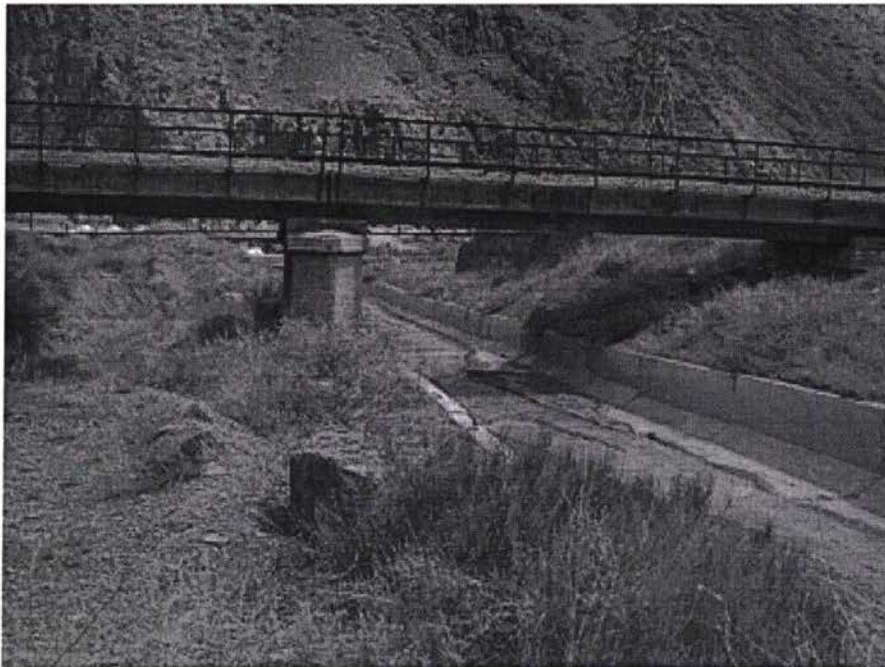

A second bridge, which needs rehabilitation works, is located between the stations of Kant and Ivanovka, crossing Konda river, a left tributary of Chu river (Fig. 2.5 - 3).

Fig. 2.5 – 3 - Bridge on Konda River

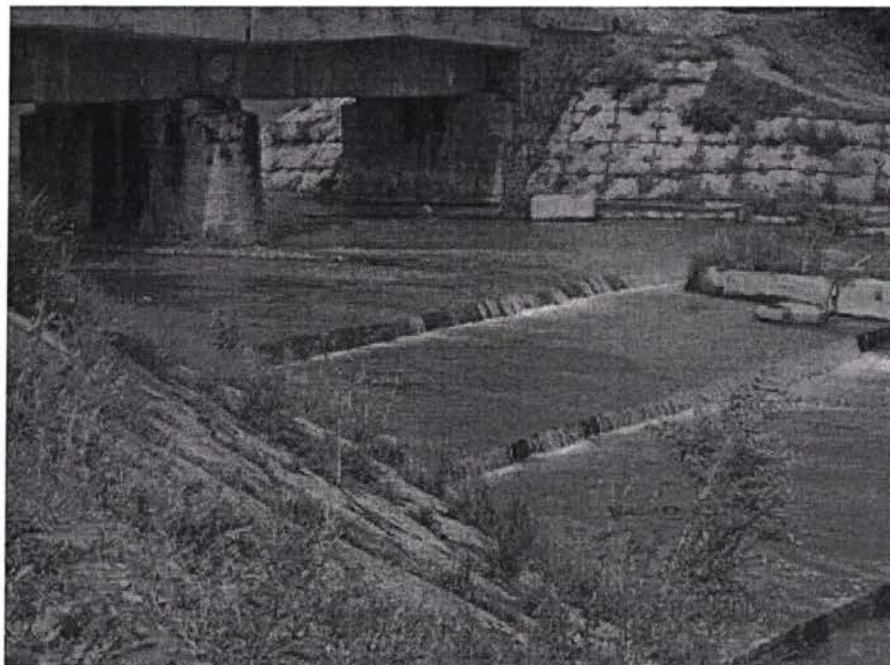

The bridge has a 2x6m scheme: 2 spans, each of them equipped with 2 beams 6 meters long.

The bridge piers need rehabilitation works and beams in bad conditions have to be replaced. However the abutments and piers foundations appear adequately safeguarded against river scouring by the existing rock walls protection of the river banks and the concrete weir across the stream.

The above mentioned interventions are similar to those needed for other three bridges located at the chainages km 3694+10, 3708+5, 3765+6, on Bishkek-Balykchi section.

2.6 Avalanche shed

On the Balykchi – Bishkek section, between the station of Djil Arik and R148 block post, two avalanche sheds are located.

The structures has been realized with a retaining wall of irregular concrete blocks, upstream, and pillars realized with regular concrete blocks fixed in a hole having the same size of the pillar, downstream. A concrete slab as roofing and foundations not connected by beams complete the structure. The link between pillars and foundations is implemented with the so-called “glass system”, without armature, while the edge beams simply lay on the top of pillars.

The stability of the described structures has to be considered critical, seeming sufficient for the line protection against land slides and falling rocks, but inadequate to bear the horizontal actions due to earthquakes.

On the mountain side of the first avalanche shed a landslide occurred, after rains during past winter (see Figure 2.6 - 1).

The geological formations involved in the landslide appear to be poorly cemented reddish conglomerate, red clay and sand, probably of Neocene age (see Figure 2.6 - 2).

Figure 2.6 - 1 – Avalanche shed with landslide on the back



Apparently the landslide is pushing on the reinforced concrete back-wall of the shed, however no signs of disruption or damages are visible on the wall. Pools of water were present on the surface

of the slide area during the site visit (see Figure 2.6 – 3) but drainage wells built from the same wall and reported to be about 10 meters deep, were dry.

Figure 2.6 - 2 – Closer view of the landslide



Figure 2.6 - 3 – Pools of water on the landslide surface



Considering the criticality of the situation, the Consultant strongly recommends to implement prevention measures against the possibility of further development of the landslide. These measures should possibly include the following works:

- remodelling of the slope shape, by reducing the soil load at the head and possibly enlarging it at the toe of the landslide;

- surface drainage of the slide area by means of a drainage ditches of adequate dimensions and gradient for discharging rain water;
- subsurface drainage with the use of subsurface drainage borings.

The structure of the second avalanche shed has been constructed in part and then stopped for shortage of funds (see Figure 2.6 – 4).

Considering the immanent risk of rock falls from the steep slopes uphill of the railway, the completion of this shed should be urgently implemented.

The related civil works for the completion of the avalanche shed are included in Lot 3.4.

Figure 2.6 - 4 – Disconnected rock slope above the avalanche shed

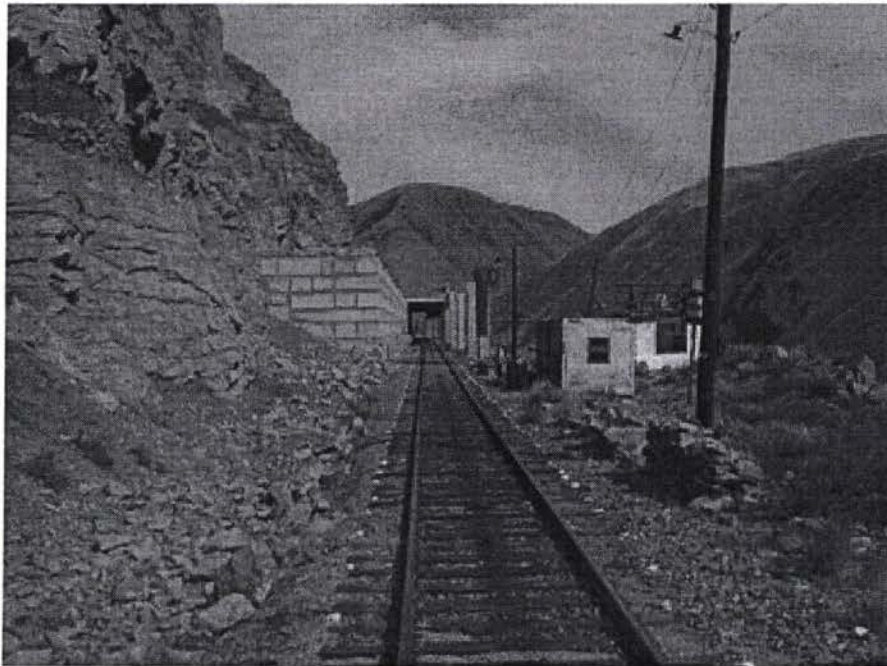

2.7 Ballast quarry

The Consultant's experts visited the only quarry in Kyrgyzstan in service for production of ballast for railways. Kyrgyz Railways are the owners of the plant and entitled to exploit the concession.

The quarry is located near the station of Djil Aryk. The quarried material is a pink coloured, good quality granites rock, fine-medium and medium grained and affected by variously oriented, dense jointing systems (see Figure 2.7 - 1). The joints disconnect the rock mass into blocks of dimensions ranging from approximately few dm to more than 1 m³.

According to information obtained on site, the quarry concession regards an estimated total quantity of material of 100.000 m³, but very big quantities of material of the same quality exist nearby.

Figure 2.7 - 1 – Quarried granitic rock



The existing crushing plant is basically composed of a jaw breaker for the primary crushing of the quarried rock to obtain ballast material and of a gyratory breaker for the secondary crushing, to obtain sub ballast material.

Figure 2.7 - 2 – Existing crushing plant



Conveyer rubber belts on straight rollers transport the material from one breaker to the other. Between the two breakers a screening station, with rotary screens, selects and separates the different materials. The coarser portion of the material (ballast) is transported to the stocking area through the conveyer belts, while the remaining portion is conveyed to the gyratory breaker for the

secondary crushing. Again a screening station downstream of the gyratory breaker selects and divides the sub ballast material from the finer material (sand and grit). The sub ballast is then conveyed to separate stock areas.

From the preliminary examination of the plant and considering the granites nature of the rock, rich in quartz, a high degree of wearing of the crushing machinery may be expected; more particularly, not considering the engines of the various apparatuses, the components of the plant mostly subjected to wearing are:

- the shell that covers the jaws of the jaw breaker and the internal elements of the gyratory breaker (hammers and internal shells);
- the conveyers rubber belts;
- the straight rollers, mainly those adjacent and below the screening and crushing stations;
- the metallic net of the screening system;
- the ball bearing of the engines (crushing and screening system);
- all the electrical apparatuses (electric panel and cables);
- wells and washing system (if existent).

Finally it has to be remarked that the crushing plant appears under utilized: 250 m³ possible daily production against only 12000 m³ of yearly production for track maintenance.

3. Description of the designed improvements

The envisaged works for line rehabilitation are as follow:

- a. Civil works concerning earthworks;
- b. Permanent way replacing works;
- c. Existing permanent way rail welding and tension regulation;
- d. Re-alignment, leveling and ballast cleaning on the existing sections;
- e. Civil works concerning structures (bridges and avalanche shed);
- f. Civil works concerning re-pavement of some level crossings (L.C.). In terms of level crossings no elimination has been envisaged for the low traffic both on the railway line and on the interfered roads (mainly unpaved roads).

The following Table 3-1 gives a short description of the different works.

Table 3-1 – Infrastructures works for line rehabilitation

Code	Works	Description
1A	Topographic survey of the line and corrections of the existing alignment and profile.	Topographic survey to be carried out along the line, for a strip of 50+50m around the existing railway axis, production of the current status cartography, and detailed correction of the alignment and profile of the line. New plan profile in scale 1:1,000 and current cross sections of the line in scale 1:200-1:100 step 50 m will be produced, indicating the existing and future geometrical parameters of the line.
2A	Demolition of line.	It consists in dismantling the existing worn out permanent way (rails, junctions, sleepers and fastenings), transportation of the materials to the deposit sites, dividing them into scrap and re-usable materials (residual value). This operation will be presumably carried out according to the methodology developed in this area: after having manually eliminated the fish-plated junctions of the rails, the dismantling train will pass over the free track panels, and its tail equipped with a dismantling crane will dismantle the track panels and automatically transport them into the front platform wagons.
3A	Excavation.	After having dismantled the permanent way, excavation of about 50-60 cm of topping material of the embankment by means of machine (bulldozer with front shovel). Generally, during this process, old polluted ballast and old polluted sub-ballast (sandy gravel) are discharged on embankment side for their future re-use. In case this work takes place into stations, the removed top material will be transported to dump. This item also includes the further compaction of the top layer of the embankment for increasing its bearing capacity and for re-shaping the embankment roof.

Module B – Detailed Design and Tender Documents of the rehabilitation measures for the Balykchi – Bishkek – Kazakh Border railway section (Kyrgyzstan)

4A	Partial lateral rebuilding embankment section, placing and compacting the removed top material for widening the top surface of about 1,0 m on both sides.	This item will be applied only on those sections where the existing embankment is found to be eroded and not compliant with the typical cross section. In many cases in fact, ballast is falling on the embankment side for the embankment is reduced in transversal dimensions due to the water and wind erosion of its slopes, not protected by means of grassing. For this item, material will be taken from the side material demolished in Item 3A for those sections where 3A took place, while for the other sections material will be transported or taken from the surrounding environment after tests. In order to widen the embankment side, the existing eroded side will be shaped in steps, and the additional earth will be added in layers of max 20-30cm in order to compact it by means of manual vibro-compacting machine.
5A	Implementation of a layer of sandy gravel material, 0,2 m thick under sleepers (sub-ballast).	After the item 4A, on the compacted top layer of the embankment the new layer of sandy gravel (sub-ballast) will be laid and compacted in the correct shape, according to typical cross section.
6A	Construction of line.	After the item 5A, the new track will be built (sleepers, fastenings and rails), by laying it on the sub-ballast layer. This procedure will be presumably carried out with the system used in this area, described in detail in the Figure on the next page. This system is based on the use of construction train, similar to the dismantling train, with opposed operations. Tail locomotive of this train will push the front laying crane against the section to be built, and the crane will lay track panels, previously assembled in station, on the sub-ballast layer. Provisional junctions will be installed and the construction train will run on the just installed panels. Construction of the line can also be carried out with other methods, as for example that envisaging the use of long welded rail to be laid on the two sides of the existing permanent way and the transportation of the sleepers only on the construction train. This second method allows to avoid the big number of welds to be done on field and allows to transport on field sleepers and long rails separately. The first train transporting long rails would also run during line operation, laying the new rails on the two sides, the second train would dismantle the existing permanent way, cleaning and re-laying the sub-ballast, laying the sleepers (transported by its wagons) at the correct distance and it would finally install the lateral new rails on the sleepers, with fastenings. In the next pages the two envisaged construction methodologies will be described with schematic drawings. The item 6A also includes first layers ballast spreading, tamping and lifting of rails up to 3 cm to final level.
7A	Flash-butt or thermic weld of P65 rail.	Welding of the panels by means of flash-butt or thermic system. Welding of the rails will have to be done according to strict technical specifications that will be detailed in the next phase of the study.
8A	Regulation of mechanical tension of long welded rails (l.w.r.).	After the rail welding, mechanical tensions will be regulated, according to strict technical specifications that will be detailed in the next phase of the study.
9A	Final tamping and levelling of new line.	The permanent way, so welded and regulated, will be in this phase taken to its final level and alignment by means of final tamping and levelling.
10A	Ballast cleaning on the other existing sections.	On some of the sections where existing permanent way is preserved, ballast cleaning will be carried out. Ballast cleaning concerns the existing section ballast cleaning and re-shaping, with some addition of new ballast where necessary. It can be carried out by means of automatic machines or by handwork.

Module B – Detailed Design and Tender Documents of the rehabilitation measures for the Balykchi – Bishkek – Kazakh Border railway section (Kyrgyzstan)

11A	Tamping, levelling and aligning the other existing sections with l.w.r.	All over the sections where existing permanent way is preserved, tamping, levelling and aligning will be carried out for reaching the final alignment.
13A	Excavation of ditches.	Hydraulic drainages must be cleaned and embankment side ditches must be excavated when absent, in order to protect the embankment side from water infiltration and foot erosion. In general, no concrete cover is requested for the ditches. Trapezoid ditch 0.5-0.5-0.5 has a volume of 0,5m ³ /m.
14A	Pavement of level crossings.	This item concerns the reconstruction of the pavement of the level crossings for the area of railway crossing only. It has been estimated that each level crossing envisages an area of about 50m by 10m.
22A	Renewal of bridges beams.	Replacement of beams and base plates
23A	Maintenance of piers and abutments.	Rehabilitation of reinforced concrete structures, and of masonry and stone pitching works on the abutments.
26A	Construction of avalanche shed.	Completion of avalanche shed and measures to improve the existing sections: connecting the plinth with reinforced concrete foundation beams and doing the same thing at the head of the pillars.
27A	Quarry rehabilitation.	Upgrading of the ballast quarry up to the production needed to the Kyrgyz Railways for rehabilitating the line section.

The adopted option by the Feasibility Study considers that all activities (but major civil works like for the bridges and for the avalanche shed) will be basically carried out by the Kyrgyz Railways personnel during a sort of extraordinary maintenance which will be possible after purchasing materials, machines and plants.

Therefore four Lots have been considered for international tendering:

- Lot 3.1 – Purchase of machines
- Lot 3.2 – Purchase of Permanent Way materials
- Lot 3.3 – Purchase of a sleeper factory
- Lot 3.4 – Civil works

Thus Lots 3.1 and 3.2 regard the purchase of those materials and machines which are needed for the rehabilitation works carried out directly by the Kyrgyz Railways. Lot 3.3 is for purchase of a sleeper factory and Lot 3.4 regards civil works (bridges, avalanche shed and quarry rehabilitation) both will be performed by a Contractor under a Design-Build and Turnkey contract.

Lot 3.4 also includes the rehabilitation of the ballast quarry near Djil Aryk in order to reach a proper level of efficiency and increase the production needed for the rehabilitation of the railway track.

As the works will be mainly carried out by the Kyrgyz Railways as extraordinary maintenance, for such maintenance there is not need to detail more the methodology of works while materials standards are duly described in the Technical Specification for Lot 3.2 (Purchase of permanent way materials).

The Consultant has deemed important to detail more some specific methodologies for the implementation possibly introducing European methodology or comparing European methodology with the CIS methodology.

3.1 Methodology for the line construction (Permanent Way)

3.1.1 Methodology 1

Hereafter the procedure commonly used in Europe to implement these works with heavy machines is described (see also Figure 3.1.1-1 here attached):

Figure 3.1.1 – 1

METHODOLOGY 1 FOR TRACK REPLACEMENT

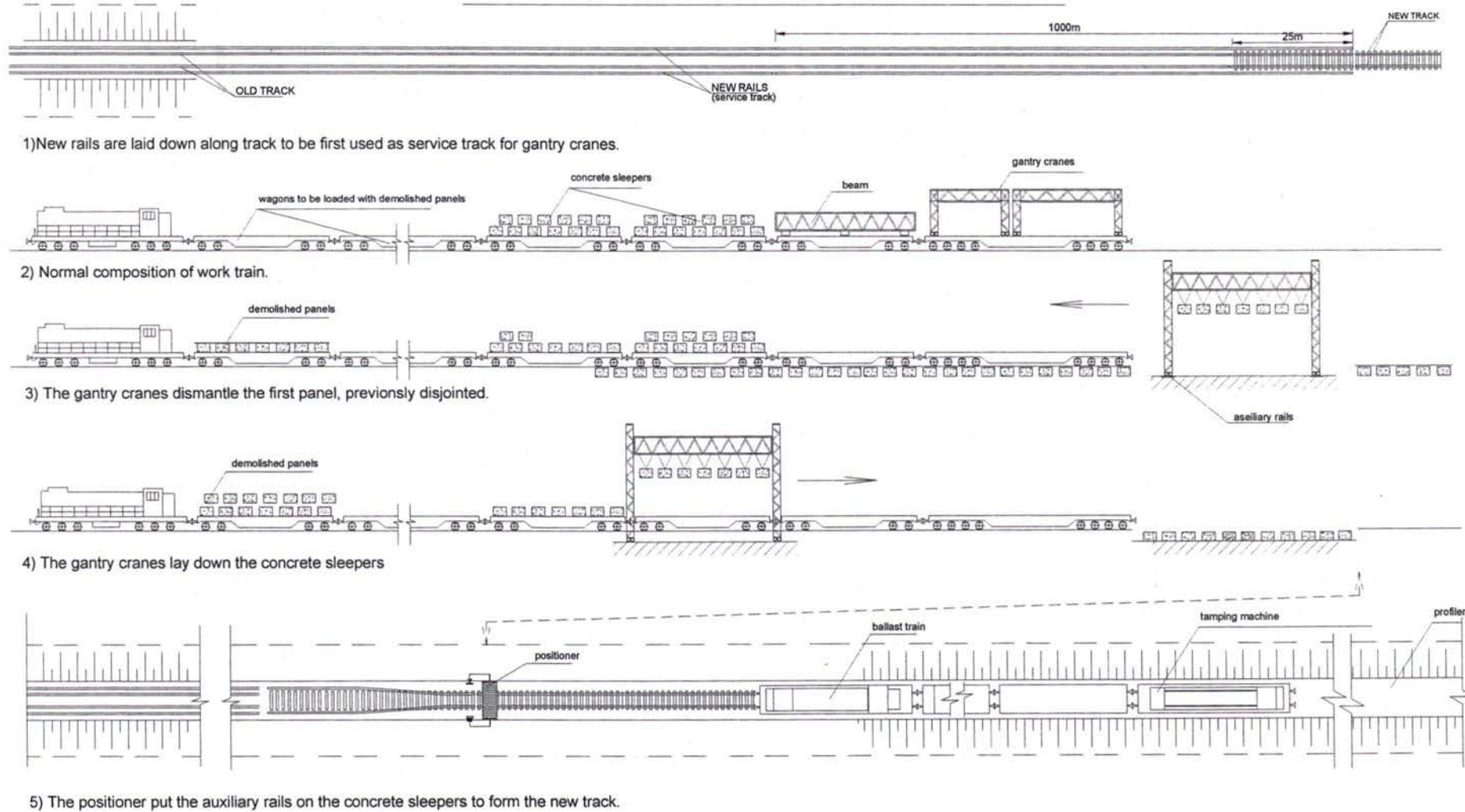

Previous activities

- I. the P65 rail bars 25 m long are welded in bars of 100+125 m and staked,
- II. the long P65 rail bars are loaded on platforms, transported and laid down along the line on both sides of the existing track, positioned and jointed to be initially used as service track for portal cranes,

Activities to be done in the same day

- III. a work train arrive at the beginning of the stretch scheduled to be dismantled and rebuilt with P65 rails on concrete sleepers (in this case the average length of this stretch is 600 m per day). The work train is formed by:
 - o platforms loaded with 2 self moving portal cranes and an ancillary beam;
 - o platforms to be loaded by dismantled 25 m track frames;
 - o platforms loaded with concrete sleepers to be installed.
- IV. the portal cranes and ancillary beam, unloaded from the platforms, displace themselves on the service track, stop in correspondence of the first 25 m panel, previously disjointed from the adjacent ones, lift it and, coming back along the train, unload it on a flat wagon; this operations are repeated up to complete the dismantling of the scheduled length of track (see also item 2A);
- V. the excavation of the existing materials start and go on until the design depth is reached (see also item 3A);
- VI. the sandy-gravel material is spread on the surface between the service rails and compacted (see also item 5A);
- VII. the portal cranes by means of the ancillary beam lift the concrete sleepers from wagons, run along the service track and lay down in two phases the concrete sleepers on the sandy gravel layer (distance between sleeper axles = 0,54 cm, that is 1840 sleepers per km are to be laid down) up to cover the full length of the dismantled stretch; at this stage reference stakes shall be used for locating the track CL and avoiding abnormal adjustments in a further stage;
- VIII. the portal cranes and beam are re-loaded on their wagons,

After placing the polyethylene pads on the rail seats of the sleepers, using a little machine called "positioner" the P65 rails, forming the service track till the present phase, are put in their definitive position on the concrete sleepers and fastened; at this stage 50% of fastenings will be inserted, the joints shall be assured with additional bolts

The new track shall be, manually and/or using the tamping machine, leveled, aligned and put in order to allow the passage of trains at a temporary speed limit of 10 km/h,

Activities to be done in the following period

- IX. The long bars are welded up to a length of 400 m (temporary section); the joints may be welded by "thermic" or flash-butt process,
- X. the finishing of the excavation and of the sandy gravel layer on both external sides is implemented,
- XI. about 1 m³ of ballast is laid down and the track lift of about 0,20 cm using the tamping machine and jacks,
- XII. additional quantities of ballast are laid down and the track is lift up to reach a level of 0+20 mm to the design level,
- XIII. during the lay down of additional ballast, the lifting and tamping operation, the ballast section profile shall be adjusted by a "profiler" machine, equipped with a brush for clearing the track,
- XIV. before final lifting, straightening and leveling of the track, the following activities have to be carried out: the regulation of the mechanical stresses of the rails, the formation of the continuous welded rails (CWR), adjust the expansion joints and fix the 100% of the fastenings.

XV. a final tamping of the complete track has to be carried out, making use of an heavy tamping machine, at least 60 days after all the works described in the above paragraphs have been successfully completed. The final line profiling has also to be implemented at this stage.

The individuation of number and type of machine to be purchased under Lot 3.1 has taken into account the just described methodology.

3.1.2 Methodology 2

Hereafter the procedure commonly used in CIS countries to implement these works with heavy machines is described (Figure 3.1.2-1, Figure 3.1.2-2, Table 3.1.2-1):

Fig 3.1.2 – 1 Main work schedule in the major repair works on track

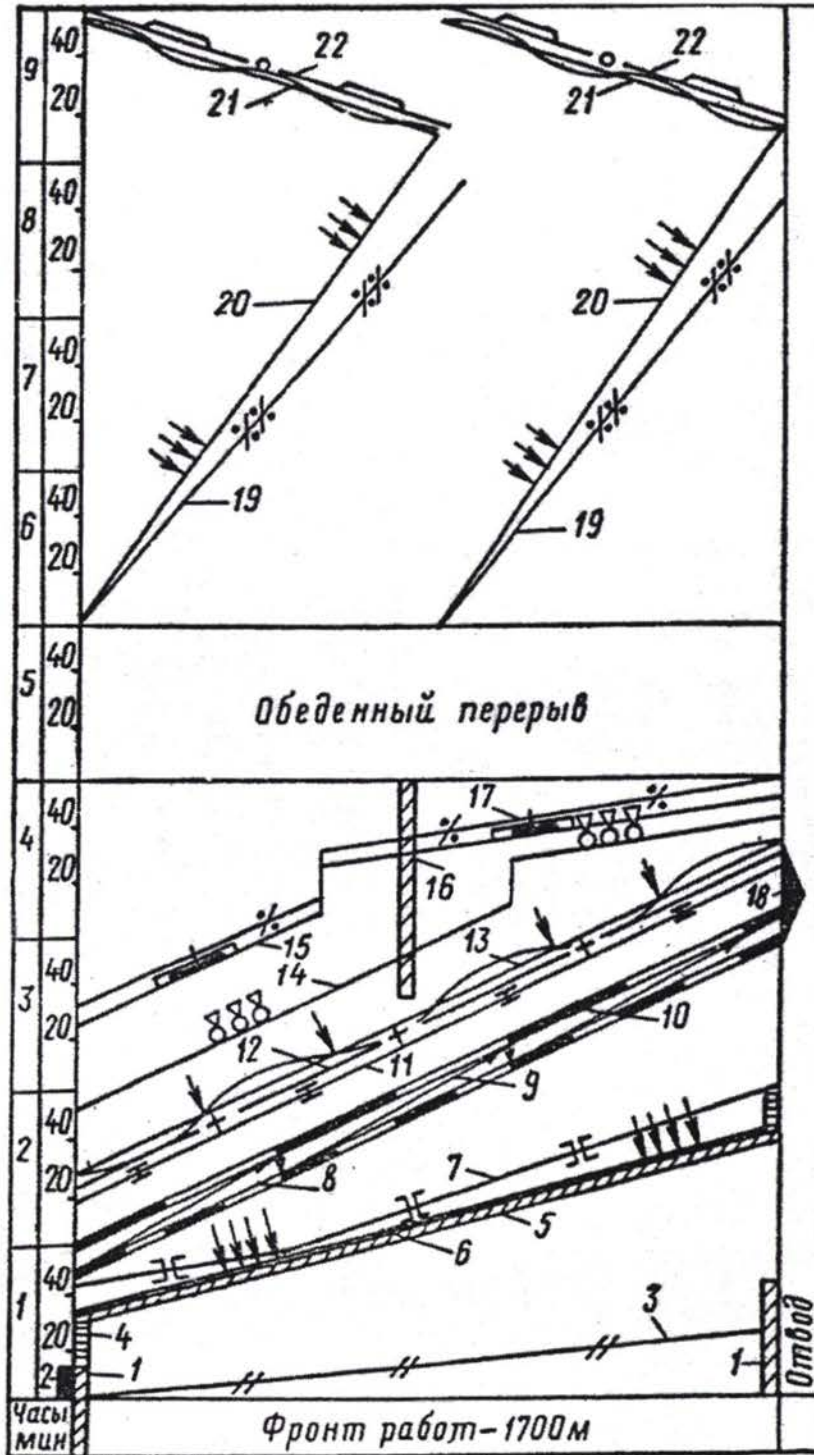

1 – preparing for charging and discharging of gravel-cleaning machine; 2 – securing the closure of the route section; 3 – preparing for dismantling; 4 - preparing for charging and discharging of gravel-cleaning machine; 5 – gravel cleaning; 6 – track rectification; 7 – unbolting the rail joints; 8 - dismantling of the track; 9 – gravel ploughing; 10 – track laying; 11 - bolting the rail joints; 12 – installing inventory stop brakes; 13 – setting the track on axle; 14 – gravel unloading; 15 – track rectification with VPO-3000 machine; 16 – equipping electrically-failed joints; 17 and 19 – exit of stop brakes; 18 – exhaust unit; 20 - track rectification; 21 - lining of the track; 22 – prism alignment.

The following table contains detailed timing of each phase of the works.

Table 3.1.2 – 1 Operational main work schedule in "possession"

N.	Operation name	Planned time	
		Duration (min)	End of operation, Hours and minutes
	The passing of the last scheduled train on station		10.40
	<i>The work of the dismantling train</i>		
1	Arrival to the place of work	15	10.50
2	Positioning in running order	8	10.58
3	Dismantling of first packet (gravel-cleaning machine's work start)	12	11.10
4	Dismantling of second packet	12	11.22
5	Same, third etc	12	11.34
22	Dismantling of twentieth packet	12	14.58
23	Positioning in transport order	12	15.10
24	Departure of dismantling train	5	15.15
	<i>Gravel-cleaning machine's work</i>		
1	Arrival on track	5	11.15
2	Gravel cleaning on the first section extending over 50 m (beginning of track laying)	5	11.20
3	Finishing gravel cleaning	225	15.00
4	Derailment	5	15.05
	<i>Laying train work starts</i>		
1	Following to the place of work	20	11.10
2	Positioning in running order (start of laying)	10	11.20
3	First packet laying	12	11.32
4	Same, second etc	12	11.44
22	Twentieth packet laying	12	15.20
23	Exhaust unit positioning of crane in transport order	10	15.30
24	Departure for station	3	15.33
	<i>Hoppers-dozers work</i>		
1	Following to the place of work of welded structure from 40 hoppers-dozers (start unloading)	15	13.00
2	Ballast unloading during track laying		15.20
3	Unloading after track laying		15.35
4	Departure of welded structure from 40 hoppers-dozers for station		15.40
	<i>The work of VPO-3000 machine</i>		
1	Following to the place of work	15	13.35
2	Charging	5	13.40
3	Machine's work during gravel unloading		15.40
4	The finishing of the measured shovel-packing		15.55
5	Machine discharging and leaving for station	5	16.00
	<i>Hoppers-dozers work</i>		
1	Following to the place of work	15	14.00
2	Ballast unloading		16.15
3	Departure of welded structure from 40 hoppers-dozers for station		16.20
4	Time route section is closed	from 10. 40 until 16.40	

Fig. 3.1.2 – 2 Current Permanent Way replacement cycle

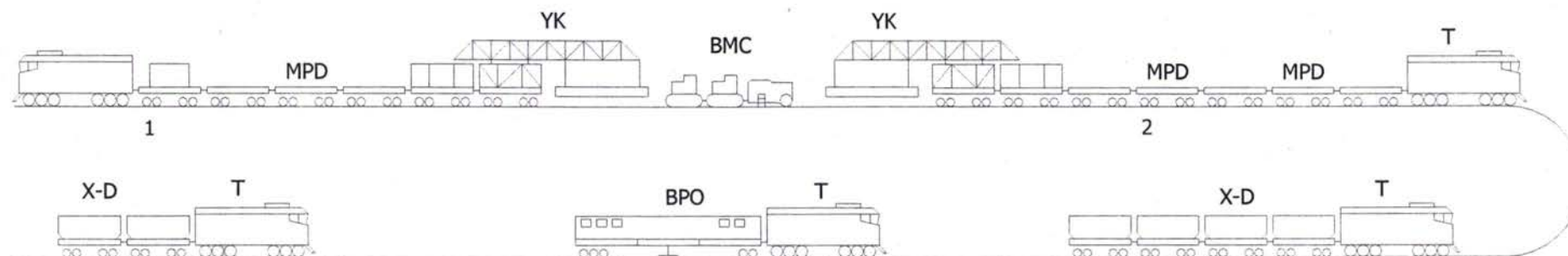

1 - dismantling (distributor) train; 2 - packing (laying) train; T - diesel locomotive;
MPD - motor platform; YK - laying crane; BMC - balast dearer; XD - hopper-batcher;
BPO - liner-tamper supfaser.

Previous activities

- I. panels 25 meters long of concrete sleepers fastened to P65 rails are prepared in a station near the work site and loaded on the laying train,
- II. a dismantling train and a laying train (loaded with the new panels to be installed), coming from one of the adjacent stations, are placed astride the first panel to be dismantled; every train has a crane on the queue of the composition, able to work on the site of this panel,
- III. the crane of the dismantling train lifts the first panel, whose joints have been previously unbolted, and, with a backward movement, lays it on a mobile device under crane on the platform wagon; this operation is repeated according to the possibilities given by the height of the crane, after a train displacing in successive positions correspondent to the other panels to be dismantled,
- IV. the mobile device, pulled by the rope of a winch, transfer on rollers the panels stacked on it to wagons in a rear position to allow the dismantling and stacking of more panels,
- V. on the dismantled stretch, excavation works start, using ballast cleaner machine, soil moving machines, motor grader, pneumatic-tired roller, leveller, to prepare the new sandy-gravel layer, if it is foreseen by the design, and /or a levelled ballast surface,
- VI. the crane of laying train, lays down the 25 m long new panels assembled P65 rails fastened on concrete sleepers, and provisional joints of panels are performed,

Activities to be done in the following period:

- VII. new ballast is spread along the line and the tamping machine start to compact ballast and to lift the rails up to 2+3 cm from the design level,
- VIII. rails are welded in 800 m bars and provisional joints recovered,
- IX. during the lay down of additional ballast, the lifting and tamping operation, the ballast section profile shall be adjusted by a "profiler" machine, equipped with a brush for clearing the track,
- X. before final lifting, straightening and levelling of the track, the following activities shall be carried out: the regulation of the mechanical stresses of the rails, the formation of the continuous welded rails (CWR), adjust the expansion joints and fix the 100% of the fastenings.
- XI. a final tamping of the complete track has to be carried out, making use of an heavy tamping machine, at least 60 days after all the works described in the above paragraphs have been successfully completed. The final line profiling has also to be implemented at this stage.

This methodology requires a number of machine and equipped wagons bigger than the previous one. Due to the shortage of efficient equipment of the Kyrgyz Railway it is suggested to adopt the previous methodology.

3.2 Methodology for rail welding

According to the information collected, the habit in CIS countries is not to weld rails on site but in the workshops. The length of the section to be considered is therefore limited by transport constraints (up to 800 m of long welded bars).

The European experience proves that rail welding can be performed on site by either of two methods:

- Thermic process
- Electric process

Within Lot 3.1 the purchase of a welding machine has been included.

3.2.1 Thermic welding

Type - The thermic welds shall be of the “rapid” type with prefabricated moulds and oxygen activated preheating.

Material and Equipment – The moulds shall be of the prefabricated type and suitable for P65 rails; they shall be stored in the cardboard boxes in which supplied.

The welding portions shall be of the type suitable for welding, with normal welding gaps, P65 rails in workshop or on site.

They shall be packed in sealed bags bearing in print the characteristic data: type of weld (“rapid”), type of rails and of steel. It is not allowed to use welding portions whose packaging has been tampered with and nothing shall be empirically added to or removed with welding portions. Should it be found necessary, in particular cases recognized as inevitable by the Works Director, to weld with wider gaps than specified, use shall be made of the appropriate welding portions.

Pre-heating shall be done by means of a suitable oxy-propane burner.

Particular care shall be taken in the storage of materials; the welding portions and the moulds shall be stored in a dry room away from inflammable materials; the oxygen cylinders and propane bottles shall be stored in isolated rooms and apart from each other. The welding equipment may be stored in the room where the welding portions and moulds are stored.

Operating procedures – The gap between the rail ends to be welded shall be between 15 and 16 mm or as specified by the manufacturer of the welding portions.

The rail ends shall be perfectly aligned in both the horizontal and vertical plane. To compensate for lowering due to thermal contraction, the two rail end sections shall be raised by 1 mm. The alignment shall be maintained during welding by inserting steel wedges. The rail ends shall be cleaned with a wire brush and any moisture dried by using the burner.

The welding casting shall not be poured directly into the mould but through a casting pocket. The slag shall be collected in an appropriate box.

The burner shall be accurately centred on the welding gap and placed with the orifice 40 mm above the running surface of the rail.

During the pre-heating, the oxygen and propane pressures shall be respectively 5 kg/cm² and 0.5 kg/cm². The pre-heating shall last not less than 6 minutes.

The procedures for the subsequent operations, from the ignition of the portion through removal from the moulds, are left to the worker’s experience and skill.

The feed head may be removed by hammer and chisel or by a hydraulic press fitted with a suitably shaped chisel. The chiselling operation shall not result in the removal of material from the essential part of the welds.

The side surfaces and the running surface of the rail head shall be ground down by means of a suitable grinder to the normal rail profile.

On the remaining parts of the rail section the presence of the weld bead remaining from the chiselling operation shall be tolerated, after removal of the feed head and of the other superfluous parts of the weld casting, the welded joint shall be cleaned with a wire brush and protected by rust-proofing paint over a length of 20 cm.

Sample Testing and Checking

- I. **Moulds:** visual inspection for integrity shall be performed on a 4% sample of each stock of welding moulds.
- II. **Portions:** two portions chosen by the Works Director shall be taken from each stock and two welds shall be executed on two pairs of rail sections, each 0,75 m long, so as to obtain two samples with a welded joint.
- III. **Bending test:** samples shall be subjected to the bending test in accordance with the following sketch:

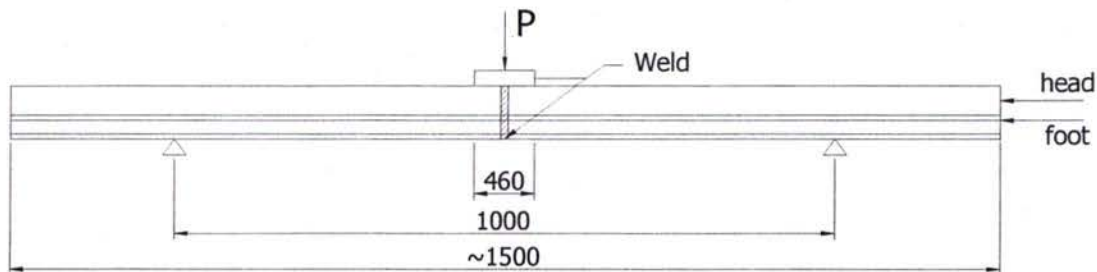

Load P shall be increased slowly from 0 to 40 tons, continuously recording the deflection of the mid portion. Under the maximum load neither cracks nor fractures shall appear. After removing the load, the residual permanent deformation shall be measured one hour after the test.

- IV. **Internal sections:** the specimen shall be cut through the centre of the weld along a plane perpendicular to the longitudinal axis and then along the plane of symmetry of the rail sections. The sulphur print of the cross section shall be taken. Inspection of the sections shall show no cavities, internal damage or porosity. At the Works Director's absolute discretion, a light degree of porosity internally to the web and head may be tolerated.
- V. **Brinell hardness:** on the longitudinal section, 5 mm under the surface the hardness shall be measured over a 300 mm length. The Brinell hardness shall be comprised in the range of 20 units less to 40 units more than that measured on the steel of the original rail. The hardness test shall be performed with a steel ball 10 mm in diameter pressed against the steel with a load rising from 0 to 3000 dN in 30 second. The impression shall be spaced to 10 mm intervals.
- VI. **Other tests:** any other test required by the Works Director with a view to determine the quality of the material used for thermic welding may be carried out. In the event of failure the weld shall be rejected.

Manufacture Checks and Tests

Each stock of welding portion supplied shall be accompanied by a certificate issued by an official testing Institute of the manufacturer's country, showing the results of the following tests performed on rail section welded with one of the portions from the stock, following the same procedures above outlined:

- bending test (see the preceding III. Paragraph)
- Brinell hardness (see the preceding IV. Paragraph)
- Sulphur prints of the weld cross section, and
- Chemical analysis which shall show that S and P contents not exceed each 0.05% and combined 0.09%.

Systematic Weld Checks

The following checks shall be performed on the welds executed in workshop or on the line:

- Visual check - A perfectly straight ruler 1,0 m long, accurate to within 1/10 of 1mm, has to be used for lining and levelling the welded joint; the check shall be done over a length of 1 m centred on the weld and defects shall not exceed those shown in the drawing in Appendix 1,
- Visual check for the integrity of the weld,
- Ultrasound check by means of a special apparatus operating above the 3 MHz frequency

3.2.2 Electric Flash-butt Welding

Rail welding machine

The welds are executed by a welding machine that may operate either on track along the line or in the station yard.

The welding head shall be suitable for welding P65 rails and perform the following functions:

- grabbing the rail ends over a sufficient length to ensure good alignment and hold them tightened with great force for the entire duration of the process,
- heating the rail ends and bringing them to the upsetting state,
- upset-welding the rail ends with the necessary force,
- allowing the mechanical removal of the welding bead,
- leaving the rail with the joint in good alignment and condition.

All the welding process shall take place automatically without the intervention of the operators whose only jobs shall be to prepare the rails, remove the welding beads and finish the rail head surface.

After the mechanical removal of the bead produced by upsetting the head surfaces shall be finish-ground with a grinding machine, as required for the thermic welds.

For the acceptance of the welds the welding machine shall be equipped with a special apparatus recording the following data for any weld:

- current absorption,
- shortening of rails due to metal fusion,
- the battering force of the welding head.

Should the recording apparatus be out of order, no welding work will be allowed.

Sample Checking and Testing

Before beginning work, two sample welded joints shall be prepared, produced with the same welding machine which will be used for the work. The samples shall have the same characteristics as those prepared by thermic welding and shall be subjected to the following checks and tests:

- visual check with 1 m metal ruler of the same characteristics as that used to check thermic welds,
- bending test as that used to check thermic welds
- internal sections as that used to check thermic welds
- Brinell hardness check as that used to check thermic welds

The machine shall be accepted if the result of the tests and checks prove satisfactory and conform to the specifications. Otherwise the machine shall be adjusted and the tests repeated until satisfactory results are obtained.

Systematic Weld Checks and Tests

Every flash-butt weld is subjected to:

- a. visual checks as that described for thermic welds
- b. integrity check

3.2.3 Formation of Continuous Welded Rails (CWR)

The purpose of forming CWR is to eliminate all rail joints and creating in the rails an even condition of thermal stresses in order to prevent thermal expansion (stress settling). The temperature at which the CWR is formed is called **neutral temperature** (zero stress at all points of the rail), hereinafter abbreviate as NT.

No CWR shall be formed on curves with a radius lower than 350 m and in stations where they will be formed according to Works Director's instructions.

On the lines equipped with Automatic Block, the CWR is to be interrupted in correspondence of the signals and an insulated joint has to be installed to allow the correct work of the track circuits; towards and backwards two stretches 12,5 m long have to be formed using by means of two additional normal joints.

The CWR shall be formed at the NT. The conditions required to get the NT may be obtained either naturally or artificially, i.e. by natural heating or with the use of tensors.

The temperature of the rail shall be monitored for at least one year and the NT lies in the range of + 7 °C -3 °C of the average temperature. The NT shall be fixed by the Works Director at the beginning of work.

Special rail thermometers suitable for measuring rail temperatures to within 1 °C have to be available.

The forming of the CWR shall be done on days when the rail reaches the NT by natural Heating and the NT is likely to remain constant within ± 3 °C through the entire duration of the forming operation. If these conditions are not obtained, the operations shall be suspended.

In a temporary section (see paragraph IX. of the item 6A Construction of line), the 36 m long central zones are defined as **central stretches** (CS).

The CWR is formed by welding two contiguous temporary semi-sections, through the following operations:

- I. disassembling the fastenings on all sleepers, except in the CS zones of the contiguous temporary semi-sections
- II. disassembling the temporary joint between the two temporary semi-sections,
- III. lifting the rail by means of stakes, starting from the joint towards the CS and inserting every 9 m expansion rollers into the rail seats, after removing the polyethylene pads; the expansion rollers, at least 20 mm in diameter, shall be positioned with their axles perpendicularly to the rail,
- IV. jarring the rail with wooden mallet blows to facilitate its expansion and the removal of any hindrances to thermal expansion,
- V. cutting thin slices off the rail ends to allow the free expansion of the temporary semi-section; this is necessary when the forming of the latter was done at temperatures below the NT. In the event of the temporary semi-sections having been formed at temperatures higher than the NT, a makeup rail shall be inserted to fill the gap due to thermal

- contraction. The length of the makeup rail shall be not less than 3 m. The makeup rail shall be welded to either of the temporary sections ends,
- VI. having reached the NT within ± 3 °C, forming the weld gaps, quickly removing the expansion roller (starting from the CS), reinstalling the previously removed polyethylene pads,
 - VII. assembling the fastenings, starting to the joint towards the CS, of the first 40 sleepers and next of one sleeper every three,
 - VIII. welding the joint,
 - IX. during the welding, completing the assembling of the fastenings,
 - X. immediately on completion of the casting of the thermic weld, disassembling the fastenings of 46 sleepers astraddle the joint in order to allow the thermal contraction of the weld on a rail length of at least 12 m on each side,
 - XI. after one hour, assembling the fastenings disassembled in step X.

Rail pulling

When it proves impossible to form the CWR by natural heating, the use of rail tensor may be required.

The tensors shall be designed to permit the execution of thermic welds and be able of producing a 60 t pull without damaging the rails.

Stress settling and CWR forming shall not be allowed to be done at temperatures under + 10 °C.

When rail pulling is used, the following operations shall be carried out, after applying the rail thermometers to the rails:

1. same as per point I.
2. same as per point II.
3. same as per point III.
4. same as per point IV.
5. affixing a reference mark on the rail foot on the ends of the two temporary semi-sections, recording the rail temperature, calculating the elongation to be produced in the two temporary semi-sections, multiplying 0,000012 by the length of the two temporary semi-sections and by the difference between the NT and the temperature recorded on the rail,
6. applying the turnbuckles and pulling the rails till the calculated elongation is achieved, as checked by reference marks, jarring the rails by wood mallet blows to facilitate elongation and remove any interferences therewith,
7. cutting thin slices off the rails ends to allow elongation,
8. when the calculated elongation is reached, quickly removing the expansion rollers starting from the CS and reassembling the rubber pads,
9. assembling the fastenings, starting from the joint towards the CS,
10. welding the joint, continuing to pull the rail till 3 minutes after the casting of the thermic weld to compensate for the tension stress of weld contraction during weld solidification,
11. loosening and removing the turnbuckles 10 minutes after the casting of the weld,
12. disassembling and immediately reassembling the fastenings of 46 sleepers astraddle the weld

3.3 Methodology for beam substitution and rehabilitation of bridges

Beam substitution

In the present case there are only 5 small bridges to be repaired and the Lot 3.4 is supposed to be given to a construction contractor on the basis of a design and build contract. Thus the contractor is responsible for the technique to be adopted for the beam substitution.

The following should be, therefore, considered as a suggestion and should take into consideration that involves a small number of beams to be substituted (only 5 bridges) vis-à-vis a large number of machines.

Methodology for beam substitution should be that used in CIS here below shortly described.

Drawing L.3.4–1 in the attached Tender Documents of Lot 3.4 (Annex D) describes the methodology for substitution of beams of a three spans bridge.

In such case the operation considers two stages:

- I stage – replacement of the first two spans
- II stage – replacement of the third span

For bridges of two spans (which is the most common case along the line), the operation should be limited to the first stage.

Works to be carried out requires a special standard train made of two diesel loco at the ends, a platform wagon for beams, a crane (EDK-1000) including a platform wagon for the boom on rest/transport, a gondola wagon for ballast.

Stage I

Works to be carried out requires a windows of 8 hour and 20 minutes:

1. Closure of the line and work train leaving the station full loaded;
2. The train reaches the bridge;
3. The crane boom is freed and the train is divided into two parts positioned each one on the two different approaches to the bridge;
4. Ballast, sleepers and rails are removed from the two spans to be substituted near to the crane;
5. The crane removes the old beams from the nearest span, put them on the temporary site aside, replace the old beams with the new-ones;
6. The crane performs the same operation for the central span;
7. Ballast, sleepers and rails are replaced;
8. Old frames are collected and loaded on the train;
9. Loco N° 2 push platform for crane boom and gondola to form again an unique train;
10. Crane boom is fixed in the rest/transport position;
11. The train reaches a station;
12. Line is open to the traffic.

Stage II

Works to be carried out requires a windows of 5 hour and 30 minutes, operations are basically the same but only beams of one span are substituted. This stage is evidently not necessary for bridges of two spans or less.

The substitution of the beams should be operated before welding the rails in long bars.

Module B – Detailed Design and Tender Documents of the rehabilitation measures for the Balykchi – Bishkek – Kazakh Border railway section (Kyrgyzstan)

Provision of beams and relevant devices are included. All of them have to comply with the standard design of Lengiprotransmost No 557, 1969 (see Figure 3.3.1 - 1).

Figure 3.3.1 - 1

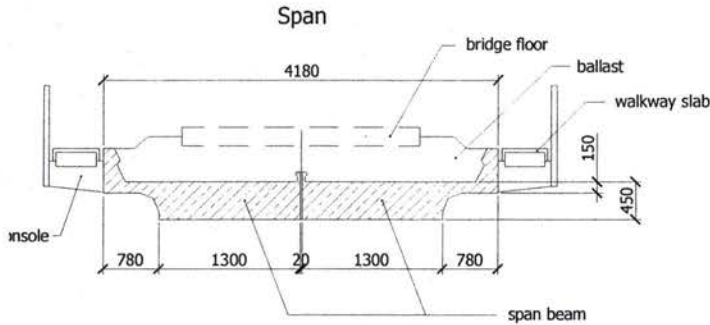

The basic parameters on one span

overall length	effective span L_p , m	Building height from a sole of a rail up to pad stone m	Mark of concrete	Volume of concrete, m ³			Weight of armature, ton			Weight of one block with isolation, ton
				of the beams	Of the walkway slab	Total	A I	A II	Total	
6.0	5.4	1.02	V-25	9.7	0.4	10.3	0.57	1.59	2.16	14.1

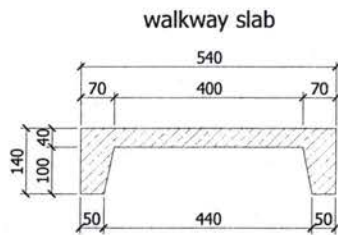

The basic parameters on one walkway slab

Mark of element	The basic sizes of elements, cm	Concrete			Armature steel	
		Mark of concrete	Volume of concrete, m ³	Weight ton	Class of the armature A I, kg	Class of the armature A II, kg
P-2	173 x 54 x 15	V-25	0.058	0.145	8.5	3.0
P-5	208 x 54 x 15	V-25	0.07	0.175	10	3.7

Waterproofing of ballast plates

Life time of reinforced concrete bridge superstructures in a great extent depends on waterproofing condition and fast water diversion from ballast plate and other surfaces of bridge superstructures.

Structure of surface waterproofing consists of preparatory isolating and protective layers (see Figure 3.3.1 - 2).

Figure 3.3.1 - 2

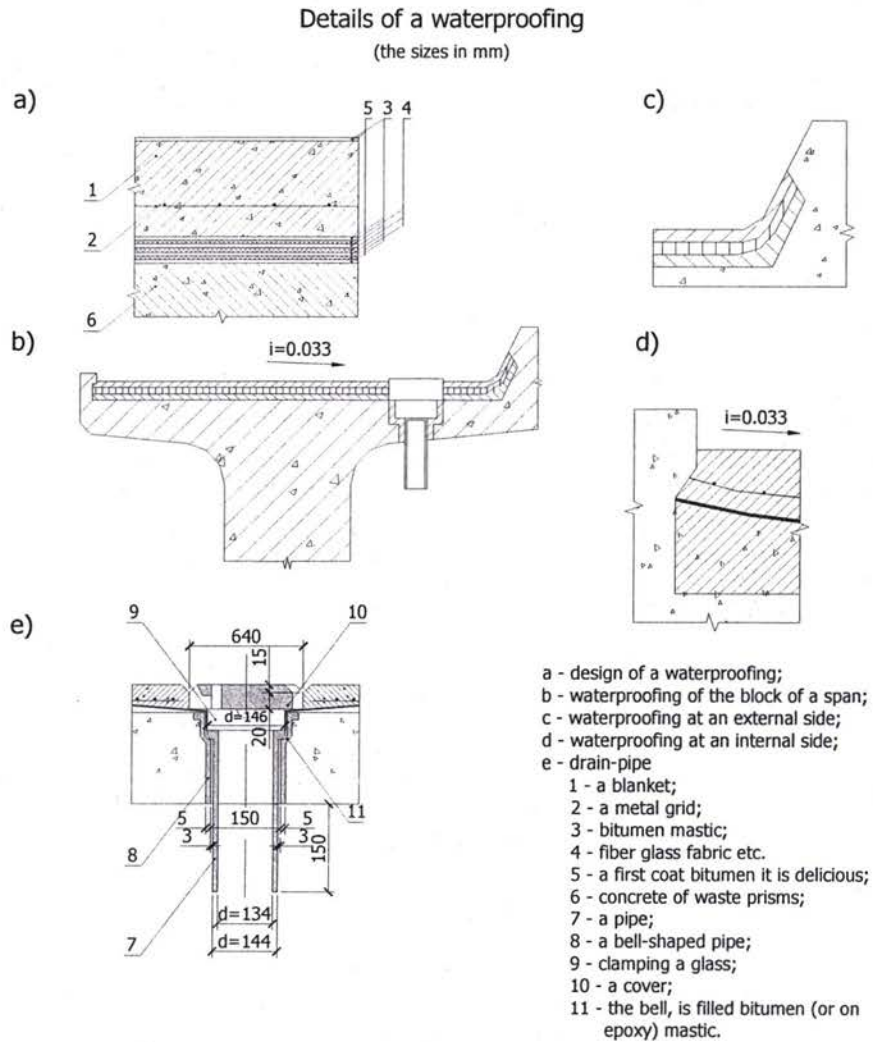

Overlapping of deformation seams

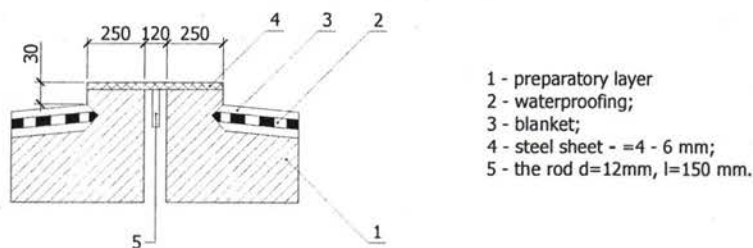

Bearings substitution

During replacement of the bridge superstructures the replacement of defective bearings is envisaged.

It is allowed to install the reinforced concrete bridge superstructures with the length of 6 m on welded tangential bearings with the height of 20 cm (see Figure 3.3.1 - 3).

Figure 3.3.1 - 3

Welded tangential carriages for slab span

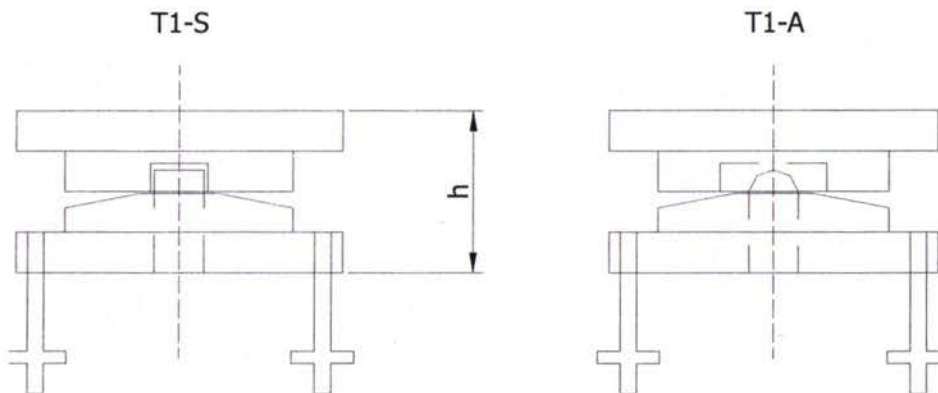

The basic parameters on one span

Height of the carriage mm	End reaction to the one carriage ton	Design movement mm	Sizes of the bottom bearing sheet		Distance between anchors along an axis of the bridge	Weight of one bearing sheet kg		Quantity of bearings on the span Lump of bearings on the span
			Along an axis of the bridge	Across an axis of the bridge		actuated bearing	stationary bearing	
200	109	25	430	310	300	164	8	1316

Repair of bridge piers

According to survey data reinforced concrete bridge structures have the following damages: cracks in the concrete, corrosion of armouring, leaching of concrete, separation of protective layer.

The following works are envisaged: cleaning from dust, dirt, leaching of concrete with rehabilitation of protective layer, trimming of cracks up to 0.15 mm with “polymer compound”, injection of cracks more than 0.15 mm with epoxy resin, improvement of waterproofing and water diversion defects on bridge superstructures is carried out from overhead rail package with the length of 5 m.

Overhaul works of piers are carried out from outside scaffoldings

Repair of abutment

Works implemented into “window” include:

- Cutting out of defective layer with the thickness of 4 cm on bearing blocks;

- Sealing up of chips with the monolithic concrete B 25;
- Dismantling of reinforced concrete laying, destroyed cordon stones;
- Installation of new reinforced concrete bearing blocks PB-1, PB-2
- Installation of new cordon blocks CB-1 and cabinet type blocks

Works implemented “under the train traffic conditions” include:

- Sealing up of chips with the thickness of 2 cm in reinforced concrete bearing blocks;
- Cement floating of abutment surface;
- Protective layer rehabilitation with cement;
- Sealing up the cracks.

3.4 Construction of a new avalanche shed

The avalanche sheds are built as follows.

The structure of the existing avalanche sheds is composed by irregular concrete blocks on the mountain side and, on the other side, by pillars made by regular concrete blocks fixed in a hole in the foundation having the same shape section of the pillar.

The basic structural element is the “concrete block”, a pre-cast concrete unity with low content of cement, used to fill up the gravity walls and with a major content of cement and in more regular shapes as active structural element, if necessary integrated with eposyc resins or structural expansion mortar.

On the mountain side, the concrete block is used both for gravity walls and for support zone of roof beams. On the other side of the gallery is used for assembling pillars and as beams supporting the roof (edge beams).

The link between pillars and foundations is implemented with the so-called “glass system”, without armature, while the edge beams simply lay on the top of pillars.

The result is a structure based on slender isolated elements, as the pillars are, that offers a poor resistance against the horizontal stresses transmitted by earthquakes.

The following measures are necessary to improve the existing structures:

- Connecting the plinth with reinforced concrete foundation beams and doing the same thing at the head of the pillars; that could be sufficient to increase the stiffness of the structure in acceptable measure.
- Performing an accurate inspection of the critical area in order to identify the most unstable rock blocks and then proceeding to their controlled removal.
- In addition to this clean up of the slopes, rock fall protection systems (like drapery wire mesh or rock-fall protection barrier) could be applied in the most endangered sections of the area.
- The cover of the structures has to be attentively controlled from time to time to ascertain its impermeability as well as the canalization for sending away the rain water.

The implementation of the 500 meters missing for the completion of the second avalanche shed has to be designed taking in due account all the structural consideration above mentioned. Before the beginning of the works, the measures above recommended are to be implemented to reduce the risk for the workers attending to the building activities.

4. Purchase of machines (Lot 3.1)

4.1 Description and bill of quantity

Number and type of machine to be purchased have decided according the rationale that Kyrgyz will be performing all activities (with the exception of works for bridges and avalanche shed) and considering the fleet of machine they own already.

Because of the involvement of a minor number of machines, the Consultant suggests to use the Methodology 1 (European) for track construction. Thus purchase of machines is in accordance with such methodology.

The following Table 3.1-1 shows the related bill of quantities.

Table 4.1-1 – Bill of Quantities

Item Description	Code	Q-ty	Unit	Note
Tamping Machine	24-A1	1	unit	including accessories, tools and spare parts
Profiler Machine	24-A2	1	unit	including accessories, tools and spare parts
Gantry Crane	24-A3	2	unit	including accessories, tools and spare parts
Positioner	24-A4	1	unit	including accessories, tools and spare parts
Loader for ballast quarry operation	24-A5	2	unit	including accessories, tools and spare parts
Welding machine	24-A6	1	unit	including accessories, tools and spare parts

4.2 Costs estimates

The capital cost has been estimated starting from the bill of quantities above mentioned (Table 4.1-1) which details the number of every specific equipment to be purchased.

In the subsequent stage, these quantities have been associated to the correspondent unit rate in order to produce the final estimation of the global capital costs of the complete lot. The unit rates reflect market prices and conditions prevailing at the beginning of 2005 and also include costs for transportation of the equipment as well as costs for accessories and spare parts and eventual costs for adaptation to the wider gauge.

Finally, as the equipment is normally exempt form taxes and duties on imported goods especially vis-à-vis funds from IFIs, all taxes have been omitted in the study.

The final cost for the whole Lot is around 8.4 millions of US\$.

5. Purchase of permanent way materials (Lot 3.2)

5.1 Description and bill of quantity

Due to the fact that Kyrgyz Railways will be performing maintenance activities, Lot 3.2 has been limited to the purchase of permanent way materials.

Quantity of permanent way material has been determined by a careful analysis of the need of rehabilitation and of the volumes involved.

As far as item 2B is concerned, the amount of sleepers considers that the sleeper factory will be operative only after 12 months and meanwhile the Kyrgyz Railways will start the extraordinary maintenance.

As for item 4B, the capacity production of the quarry is limited actually to the strict necessary for the routine maintenance. Such production will be increased by the machines to be purchased but an additional input (in terms of ballast) is necessary meanwhile in order to start extraordinary maintenance immediately. Such amount has been calculated under the assumption it will take one year before getting the machines and so modifying the production levels.

To start with extraordinary maintenance immediately is the advice of the Consultant. Of course if Kyrgyz Railways decide not to follow such suggestion it is advisable to reduce items 1B and 4B amount according to the objective needs. This will have a repercussion on the Lot cost.

The following Table 5.1-1 shows the related bill of quantities.

Table 5.1-1 – Bill of Quantities

Code	Description	Unit	Quantity	NOTES
1B	P65 rails	t	6.200	Corresponding to 48 km of single track line
2B	Concrete sleepers	unit	100.000	100,000 sleepers corresponding to 55 km
3B	Fastenings for concrete sleepers	pairs	100.000	
4B	Ballast for rehabilitated sections	m ³	40.000	Corresponding to 22 km of single track line
9B	Switch crossing	unit	100	50 for R65 and 50 for R50
10B	Switch blades	pairs	100	50 for R65 and 50 for R50
12B	Rail Joints	each	4.100	
13B	Insulated rail joints	each	1.500	

5.2 Costs estimates

The capital cost has been estimated starting from the bill of quantities above mentioned (Table 5.1-1) which details the number of every specific equipment to be purchased.

In the subsequent stage, these quantities have been associated to the correspondent unit rate (Table 5.2-1) in order to produce the final estimation of the global capital costs of the complete lot. The unit rates reflect market prices and conditions prevailing at the beginning of 2005 and do not include costs for transportation which has been included at the end at an average rate of 6% of the lot cost.

Finally, the figure doesn't consider taxes and duties on imported goods especially vis-à-vis funds from IFIs. Thus all taxes have been omitted in the study.

Table 5.2-1 Unit Costs

Code	Description	Unit	Rate (US\$)	NOTES
1B	P65 rails	t	450,00	
2B	Concrete sleepers	unit	30,00	
3B	Fastenings for concrete sleepers	pairs	20,00	
4B	Ballast for rehabilitated sections	m ³	6,00	
9B	Switch crossing	unit	4.000,00	50 for R65 and 50 for R50
10B	Switch blades	pairs	15.600,00	50 for R65 and 50 for R50
12B	Rail Joints	each	25,00	
13B	Insulated rail joints	each	34,00	

The final cost for the whole Lot is around 10.8 millions of US\$.

6. Purchase of a sleeper factory (Lot 3.3)

6.1 Description

Purpose of the tender is the supply of a sleeper factory for the Kyrgyz Railways according to the following requirements:

- the plant is to be for an average production capacity of 100.000 sleepers per year and so assuming 8 hours working shift, one working shift per day and 250 working days per years a production of a minimum 400 sleepers per working days is required;
- the plant is to be easily upgraded for the a second working shift;
- the plant has to produce sleepers 1520 mm gauge, 2700 mm length and equipped with KB fastening type, according to Standard GOST 10629;
- the plant has to produce pre-stressed concrete sleeper reinforced with improved adhesion wires.
- the manufacturing plant has to be "mobile" and so all equipment should be designed to be easily taken apart for transportation and installation at a new factory site;
- the manufacturing plant has to be equipped with safety protection in all the areas where there are machines in motion;
- different phases of the manufacturing are to be executed with computerised quality control keeping records of each critical operation;
- all components have to be first class standard certified;
- the plants should ensure the full production capacity within 4 months from the start-up.

The following ancillary equipments are not included in the request for quotation:

- a) Main electric board (machines supply)
- b) Safety devices
- c) Laboratory testing equipment
- d) Self-stressing moulds (characteristics and number are part of the proposal)
- e) Auto threading machine for steel wire preparation
- f) Auto end void grouting machine to grout the holes at the ends of sleepers
- g) Concrete batching plant, including installation
- h) Steam generator 400 steam/hour
- i) Air compressor 25 kW
- j) Fork lift truck 10 tons capacity

The Consultant's advice is that such ancillary equipments are not only for facilitating the production but also for improving the quality of the products (sleepers). If Kyrgyz Railways have not such equipment, it is advisable to possibly integrate some of those equipments in the sleeper factory supply. This, of course, will increase costs.

6.2 Cost estimate

The cost of the sleeper factory has been estimated by a market investigation.

The cost of the lot reflecting market prices and conditions prevailing at the beginning of 2005, including costs for transportation and without taxes is of about 2.0 millions of USD. The global cost for the ancillary equipment is of about 1.0 million of US\$ but it has not been included in the lot and in the relative requirements.

7. Detailed Design of Civil works (Lot 3.4)

7.1 Description and bill of quantities

Works included in this lot are:

- Substitution of damaged beams in 5 bridges;
- Maintenance of piers and abutments in 5 bridges;
- New construction of an avalanche shed;
- Quarry rehabilitation (near Djil Aryk).

Therefore description of the present situation and detailed design have been limited to those aspects included in the Lot 3.4.

It is worth mentioning that the adopted tender documents for “design and build” gives to the construction contractor the full responsibility of developing the executive design following the so called “employer’s requirements”.

The detailed design performed by the Consultant is due just for formulating the employer’s requirement and not for other elaborations.

On the contrary the construction contractor is the sole responsible of the executive design and of the works implementation. In such circumstances, the detailed design made by the consultant has to be seen as a base/advise which doesn’t prevent the construction contractor to propose other works methodology and formulate their financial proposal accordingly.

The following Table 7.1-1 shows the bill of quantity for the related works.

Table 7.1-1 – Bill of quantities

Code	Description	Unit	Quantity	Notes
22A	Replacement of bridges beams	each	18,00	4 bridges are 2X6 m span; 1 bridge is 1X6m span
23A	Maintenance of piers and abutments	each	14,00	
26A	Construction of avalanche shed	m	500	It includes measures to improve the existing sections
27A	Quarry rehabilitation	unit	1	
19B	Provision of bridges beams	each	18,00	4 bridges are 2X6 m span; 1 bridge is 1X6m span

7.2 Costs estimates

7.2.1 Unit costs

The analysis was aimed at detailing all the cost items, including foreign and national expenditures for materials, foreign and national cost for man-power, cost of the machines and expenditures for taxes, duties and Contractor and Client general expenditures.

For the Infrastructure, the construction cost is subdivided into the following types of work and expenditures in accordance with the structure of capital investments and the planned schedule of activities of constructing-and-mounting companies (Contractors):

- Materials;
- Construction works;
- Miscellaneous expenditures of a contractor;
- Miscellaneous expenditures of a customer.

A Contractor includes in the above cost both direct and concomitant expenditures (factor costs, miscellaneous expenditures, profit, and also funds for payment of taxes, duties and other obligatory payments).

Direct expenditures (including miscellaneous ones) are the expenditures of a contractor to construct a requested object that is labour and material resources, etc.

When calculating a construction cost, the following types of work and expenditures are considered:

1. Materials cost – cost of the necessary building materials, divided in national and foreign costs, according to the production Country;
2. Manpower Construction works – works on construction of buildings, different types of structures, finishing works, installation of external and internal engineering networks, installation of foundation and supporting structures for equipment, preparation a site for construction, etc.;
3. Manpower Mounting works - assembly and installation of devices at the place of their permanent operation (including inspection and individual testing of all kinds of equipment, electric installations, devices, computer engineering, connection of the equipment to engineering networks and other works);
4. Miscellaneous expenditures are the rest of expenditures not included in the factor costs for construction-and-mounting works, including:
 - Other industrial expenditures defined for a construction project (a contractor's expenditures);
 - For organisation of construction works (overhead expenses);
 - For construction of temporary buildings;
 - For performing works in winter time;
 - For long service bonus;
 - For additional leave of workers;
 - Travelling expenses;
 - For transportation of workers up to the building object;
 - For relocation of construction-and-mounting organisations;
 - For a mobile method of work performance;
 - Insurance of construction risks;
 - Obligatory payments (taxes), duties in conformity with the legislation of the Republic of Kyrgyzstan
 - Unforeseen costs and other expenditures for construction of objects.

Besides, the construction cost includes other expenditures during the construction:

- Allotment of a piece of land for construction of an object and external engineering structures;
- Fixing of points and signs;
- Demolition of structures;
- Bonus for timely and prescheduled commissioning of objects;
- Insurance of building risks;
- For banking services;
- Loan interests;
- Maintenance of a customer's facilities;
- Training of operational staff;
- Design and survey works;
- Survey works;
- Expertise of the design documentation;
- Profit necessary to cover the expenditures of a customer;
- Unforeseen costs.

The cost of the above mentioned expenditures is defined through calculations or through actual expenses of a customer and a contractor.

In the conditions of the market economy being developed in Kyrgyzstan, the prioritized importance is attached to the method of calculating a construction cost based on the cost of resources. This method of defining a construction cost is a method of calculating expenditures in current prices or forecast prices and tariffs to be incurred during a project implementation.

A construction cost in current prices is defined on the basis of resource estimates developed through the above mentioned resource method with the use of information on actual prices for resources.

The factor cost is determined based on the allocated resources in current prices by types of expenditures:

- a) wages including charges on social insurance;
- b) maintenance cost of machines and mechanisms;
- c) cost of building materials, items and structures including their transportation.

When calculating a construction cost, the level of current prices is taken on the basis of:

- wages – average statistical wage of construction workers as per the data of the State Committee on Forecast and Statistics;
- maintenance of machines and mechanisms – as per similar objects or special calculations;
- materials, items, structures, equipment - proceeding from the price level at the local and foreign markets, on the basis of wholesale prices of manufacturing factories, prices at stock exchanges and fairs of building materials.

7.2.2 Cost calculation flow

The following Table 7.2.2-1 resumes the main factors for calculation of the total cost amounts.

Table 7.2.2 – 1 Main factors for calculation of total cost amounts

<i>Rehabilitation works for Balykchi - Bishkek - Kazakh border section</i>		
<i>"General data for project cost estimation"</i>		
Transport expenditures for materials	6	%
Transport expenditures for constructions	6	%
Risk coefficient	1.15	coeff.
Other expenses and cost of contractor	15	%

Other expenses and costs of the contractor include:

- profit;
- administrative costs of the company;
- fix costs for the company;
- other general expenses.

In addition 20% taxes should be considered.

The following table resumes the cost calculation flow.

Table 7.2.2 - 2 Cost calculation flow

<i>Rehabilitation works for Balykchi - Bishkek - Kazakh border section</i>		
<i>"Project cost calculation flow"</i>		
Item	Article of expenses	Calculation method
A	Cost of construction + 6% transport	A
B	Other expenses and costs of the contractor	B=15%A
C	Total cost of construction and contractor expenses	C=A+B
D	tax 20%	D=20%C
E	Total cost of construction and contractor expenses with taxes	E=C+D
F	Risk coefficient defined on basis of forecasted index of construction price growth for the following year	F=15%E
T	Lot cost	T=E+F

The following table 7.2.2-3 resumes the result of cost analysis for the Lot 3.4 and Civil Works. It has been developed according to the detailed bill of quantities, the unit cost and the rationale above provided.

Table 7.2.2-3 Lot cost analysis

Rehabilitation works for Balykchi - Bishkek - Kazakh border section "Lot 3.4 Civil Works"		
Item number	Article of expenses	Cost (\$)
A	Cost of construction + 6% transport	5.000.000,00
B	Other expenses and costs of the contractor	750.000,00
C	Total cost of construction and contractor expenses	5.750.000,00
D	tax 20%	1.150.000,00
E	Total cost of construction and contractor expenses with taxes	6.900.000,00
F	Risk coefficient defined on basis of forecasted index of construction price growth for the following year	1.035.000,00
T	Lot cost	7.935.000,00

8. Implementation schedule

The following Table 8 - 1 shows the implementation plan for the works envisaged for the four Lots and for the activities to be carried out by the Kyrgyz Railways.

All the scheduled activities will be completed in 60 months.

**Module B – Detailed Design and Tender Documents of the rehabilitation measures
for the Balykchi – Bishkek – Kazakh Border railway section (Kyrgyzstan)**

Table 8.1 Implementation programme

ACTIVITY/months		1-2	3-4	5-6	7-8	9-10	11-12	13-14	15-16	17-18	19-20	21-22	23-24	25-26	27-28	29-30	31-32	33-34	35-36	37-38	39-40	41-42	43-44	45-46	47-48	49-50	51-52	53-60	
Lot 3.1. Purchase of machines																													
1	Approval of financemnt	*																											
2	Final tender document preparation		█																										
3	Asking and reciving offers			█																									
4	Orders of machines				█																								
5	Production and delivery of machines					█	█	█																					
Lot 3.2. Purchase of materials																													
6	Approval of financemnt	*																											
7	Final tender document preparation		█																										
8	Asking and receiving offers			█																									
9	Orders of materials				█																								
10	Production and delivery of materials					█	█	█	█	█	█	█	█	█	█	█	█	█	█	█	█	█	█	█	█	█	█	█	█
Lot 3.3. Purchase of a sleeper factory																													
11	Approval of financemnt	*																											
12	Final tender document preparation		█																										
13	Asking and receiving offers			█																									
14	Production of sleeper factory				█	█	█																						
15	Installation - tests						█	█																					

**Module B – Detailed Design and Tender Documents of the rehabilitation measures
 for the Balykchi – Bishkek – Kazakh Border railway section (Kyrgyzstan)**

ACTIVITY/months		1-2	3-4	5-6	7-8	9-10	11-12	13-14	15-16	17-18	19-20	21-22	23-24	25-26	27-28	29-30	31-32	33-34	35-36	37-38	39-40	41-42	43-44	45-46	47-48	49-50	51-52	53-60
Lot 3.4. Civil works																												
16	Approval of financment	*																										
17	Final tender document preparation		█																									
18	Tendering and signature of contract for civil works			█																								
AVALANCHE SHED																												
19	Ordering materials			█	█																							
20	Production and handing over of materials					█	█	█																				
21	Mobilisation of worksite							█	█																			
22	Execution of works - acceptance tests									█	█	█	█	█	█	█												
BRIDGES																												
23	Ordering materials			█	█																							
24	Production and handing over of materials					█	█	█																				
25	Mobilisation of worksite							█	█																			
26	Execution of works - acceptance tests									█	█	█	█	█	█	█												
QUARRY																												
27	Ordering of spare parts			█	█																							
28	Production and handing over of spare parts					█	█	█																				
29	Installation and acceptance tests							█	█																			
ACTIVITIES TO BE DONE BY KYRGYZ RAILWAYS																												
30	Rehabilitation of railway line (*)					█	█	█	█	█	█	█	█	█	█	█	█	█	█	█	█	█	█	█	█	█	█	█

(*) The detailed implementation programme is depending on availability of resources, but it is assumed to be completed within 60 months from the approval of funding.

9. Tender Documents

9.1 Introduction

Purpose of this activity is “to prepare contract packages for international competitive bidding, international shopping, and direct purchase in accordance with standards development bank procedures”.

The scope of each package depends on the recommended solutions in the Feasibility Studies (FS). The following detailed design of the recommended improvement has given the input to the tender documents preparation.

Besides the technical recommended solutions, the procurement activities are deeply affected by standard development bank procedures. Despite a common philosophy, each bank normally has its own Guidelines for Procurement or a standard document to be adapted time by time.

On the other hands, the Consultant can't produce tender documents taking into consideration all factors deriving from all the possible combination among several feasible packages and four (maybe more) standard documents (EBRD, ADB, IDB, World Bank, national).

All the above results in the following:

- each package has been prepared in accordance with requirements of the Guidelines of possible financing banks, which assure International Competitive Bidding;
- the Consultant can produce only a “draft tender document” since several details (for instance (i) tender Identification Number, (ii) Deadline for submission of the Tender, (iii) time, date and place of tender opening, (iv) date and location of pre-tender or site meeting, (v) Employer's address, etc.) are not known at the moment and will be known in the time being up to end of the project;
- several details are susceptible to be changed before the date of the tender publication.

9.2 The adopted philosophy for procurement

The Consultant has developed the philosophy for a successful procurement of the Package taking into consideration the following basic criteria.

The Standard Bidding Documents of Asian Development Bank (ADB) have been adopted.

It is noted that the Standard Bidding Documents adopted from various banks such as WB, EBRD, IDB, ADB, etc. slightly differs one each other.

In fact the above said banks have adopted since many years a policy of homogenization of the Tender Documents.

Such approach of using international standards leaves open the possibility of adopting guidelines of procurement of Institutions other than ADB.

Basically the legal relationships between the Borrower and the Bank are governed by the Loan Agreement. However, in the present circumstance, the procurement procedures are undertaken before signing the related Bank loan.

The rights and obligations of the Borrower and the providers of goods and works for the project are governed by the bidding documents, and by the contracts signed by the Borrower with the providers of goods and works.

In fact, for major contracts involving the procurement of advanced technological equipment it is common practice to develop the procurement procedures through an International Competitive Bidding (ICB).

The objective of ICB is to provide all eligible prospective bidders with timely and adequate notification of a Borrower's requirements and an equal opportunity to bid for the required goods and works.

The bidding documents shall clearly state the type of contract to be entered into and contain the proposed contract provisions appropriate therefore. The most common types of contracts provide for payments on the basis of unit prices or a lump sum.

For Lot 3.1 Purchase of machine and Lot 3.2 Purchase of materials, the ADB Standard Tender Documents (STD) for Procurement of Goods have been taken as reference while for Lot 3.3 Purchase of a sleeper factory and Lot 3.4 Civil Works, the ADB Standard Bidding Documents (SBD) for Design-Build and Turnkey have been adopted.

A. STD for Procurement of Goods.

The ADB's STD for Procurement of Goods are used for contract where the supply of goods and material prevails on the installation works and other related services.

The Single-Stage: One-Envelope bidding procedure is the main bidding procedure used for most of the procurement financed by the ADB. In the Single-Stage: One-Envelope bidding procedure, Bidders submit Bids in one envelope containing both the Price Proposal and the Technical Proposal. The envelopes are opened in public at the date and time advised in the Bidding Document. The Bids are evaluated and the Contract is awarded to the Bidder whose Bid has been determined to be the lowest evaluated substantially responsive Bid.

In accordance with ADB established procedures, prequalification of bidders is required for procurement contract related to expensive and technically complex items to ensure that only experienced and financially capable firms will submit bids.

Therefore a combination of :

- ADB's SPD for Prequalification, and
- ADB SBD for Procurement of Goods with Single Stage – One Envelope procedure

The main data provided by the Consultant are on the results of the Detailed Design, and are namely:

- For the SPD for Prequalification:
 - Short description of the project

- Major contract components
- Estimated quantities of major components
- Contract implementation period
- For the SBD for Procurement of Goods with Single Stage – One Envelope procedure:
 - List of goods and related services
 - Technical specifications of goods and related services
 - Drawings

B. Standard Bidding Documents (SBD) for Design-Build and Turn Key Contract with Single Stage bidding procedure.

There are no universally-accepted definitions of the terms "design-build" and "turnkey", except that both involve the Contractor's total liability for design. For the Employer, such single-point responsibility may be advantageous, but the benefits maybe offset by having less control over the design process and more difficulty in imposing varied requirements.

Under the usual arrangements for a design-build contract, the Contractor is responsible for the design and provision, in accordance with the Employer's requirements, of works which may include any combination of engineering (including civil, mechanical, electrical, etc) and building works; and interim payments are made as construction proceeds.

The Conditions are also intended for use on turnkey contracts, under which the Employer's requirements usually include provision of a fully equipped facility, ready for operation (at the turn of the "key"). Turnkey contracts typically include design, construction, fixtures, fittings and equipment, the scope of which would be defined."

Turnkey contracts involve the contractor's single responsibility for design, manufacture, delivery, installation, testing, commissioning, training, etc.

In the Single Stage bidding procedure the bidders submit one envelope containing the price proposal and the technical proposal. The envelope is opened in public and the total amount of each bid and any alternative bid and other relevant details are read out and recorded. The bid is evaluated and the award of contract is made to the lowest evaluated substantially responsive bidder. The Single Stage bidding procedure is normally utilized for contracts where the plant to be designed and build is very well defined or where the civil works content is very high such as for roads, pipelines and power transmission line projects where there is not likely to be problems in the evaluation of alternative proposals for machinery or equipment.

In accordance with ADB established procedures, prequalification of bidders is required for civil works, turnkey contracts and contracts for the fabrication of expensive and technically complex items to ensure that only experienced and financially capable firms will submit bids.

ADB's Standard Procurement Documents (SPD) for the Prequalification of bidders is based on Master Procurement Documents prepared jointly by multilateral development banks and other public international financing institutions.

The Tender Documents are constituted by a combination of:

- ADB's SPD for Prequalification, and
- ADB SBD for Design-Build and Turn Key Contracts with Single Stage procedure.

The main data provided by the Consultant are on the results of the Feasibility Studies, and are namely:

- For the SPD for Prequalification:
 - Short description of the project
 - Major contract components
 - Estimated quantities of major components
 - Contract implementation period
- For the SBD for Design-Build and Turn Key Contracts with Single Stage procedure:
 - Employer's Requirements. Care must be taken when drafting the Employer's Requirements to ensure that the requirements are not restrictive. In the specification of standards of goods, materials and workmanship recognized international standards should be used as much as possible. Where other particular standards are specified, whether national standards of the Borrower's country or other standards, it should be state that goods, materials and workmanship meeting other authoritative standards and which promise to ensure equal or higher quality than the standards specified, will also be acceptable. Where a brand name of a product is specified it should always be qualified with the terms or equivalent. In addition to stating the requirements of the completed Works clearly the Employer Requirements Section should also include matters related to the execution of the Works to enable the bidders to gauge the extent of responsibility and to price the bid accordingly.

10. Conclusions

Following the positive results of the Feasibility Study, the Consultant has prepared the detailed design necessary for the development of the related tender documents

Except for main civil works (bridges and avalanche shed), the rehabilitation will be performed directly by the Kyrgyz Railways using the internal personnel.

Such proposed option represents the low cost alternative, mainly consisting in provision of PW materials, machines and plants that would permit to face the most urgent necessities of the line (starting from the Kazakh border – Bishkek section), as well as in building the indispensable structures to guarantee the line protection from land-slides. It would allow the acceleration of the capital maintenance of the remaining network putting at disposal recovered rails and machines to implement works with Kyrgyz railways personnel.

Since the proposed option has been validated in meetings with high representatives of the Kyrgyz Railways, the Consultant has consequently undertaken the Detailed Design and the Tender Documents preparation.

The option considers in particular the categories in which the whole rehabilitation works can be divided to be:

- a. Civil works concerning earthworks;
- b. Permanent way replacing works
- c. Existing permanent way rail welding and tension regulation;
- d. Re-alignment, leveling and ballast cleaning on the existing sections;
- e. Civil works concerning structures (basically bridges and avalanche shed).

The activities concerning civil works for structures (bridges and avalanche shed) are to be developed by a Contractor on the basis of a design and build contract.

All other works will be performed directly by the Kyrgyz Railways using internal personnel following the purchase of materials, machines and plants.

Therefore four lots have been considered:

- Lot 3.1 – Purchase of machines
- Lot 3.2 – Purchase of Permanent Way materials
- Lot 3.3 – Purchase of a sleeper factory
- Lot 3.4 – Civil works

Lot 3.4 also includes the rehabilitation of the ballast quarry near Djil Aryk in order to reach a proper level of efficiency and increase the production needed for the rehabilitation of the railway track.

In all cases the tender should be launched using international standards (ADB standards) but the work performed, leaves open the possibility of adopting guidelines of procurement of other bodies. Thus the approach doesn't prevent the Beneficiary to implement the project using other guidelines (i.e. World Bank, EBRD, national, etc.) simply taking the core part of the tender document, namely

**Module B – Detailed Design and Tender Documents of the rehabilitation measures
for the Balykchi – Bishkek – Kazakh Border railway section (Kyrgyzstan)**

the technical drawings and specifications, and embedding them into a different set of standards documents.

For Lot 3.1 and Lot 3.2, the ADB Standard Tender Documents (STD) for Procurement of Goods have been taken as reference while for Lot 3.3 and Lot 3.4, the ADB Standard Bidding Documents (SBD) for Design-Build and Turnkey have been adopted.

The Consultant has presented such documents in separate Annexes (Annex A, B, C and D) which can be straight used for the tender just including some basic additional information from the Beneficiary (i.e. employer's name and address, representative of the employer, deadline for presentation, etc).

Finally, despite the positive results, it has to be pointed out that the project has been largely affected by the national Kyrgyz law covering "classified information".

As already explained, this heritage of the former Soviet Union prevents the access to a large series of information to foreign people including those geographically referred such as detailed maps, locations of stations/bridges/structures and including train timetable, traffic details, etc.

It is worth mentioning that such constraints could have also counterproductive effects vis-à-vis design standards required by IFIs for releasing a loan. Thus other projects could be preferred just for being better presented: for instance such constraint didn't allow the Consultant to produce plans and profiles and has required a working methodology more numerical/analytical so less intuitive.

Notwithstanding Kyrgyz Railways have always been observant of the rules, they have been also very constructive in supporting experts staff both in the site visits and in the technical discussion.